



Leica GS10/GS15

User Manual



Version 4.1
English

- when it has to be **right**

Leica
Geosystems

Introduction

Purchase



Congratulations on the purchase of a Leica GS10/GS15.

This manual contains important safety directions as well as instructions for setting up the product and operating it. Refer to "5 Safety Directions" for further information.

Read carefully through the User Manual before you switch on the product.

Product identification





The type and serial number of your product are indicated on the type plate. Enter the type and serial number in your manual and always refer to this information when you need to contact your agency or Leica Geosystems authorised service workshop.

Type: _____

Serial No.: _____

Symbols

The symbols used in this manual have the following meanings:

Type	Description
 DANGER	Indicates an imminently hazardous situation which, if not avoided, will result in death or serious injury.
 WARNING	Indicates a potentially hazardous situation or an unintended use which, if not avoided, could result in death or serious injury.
 CAUTION	Indicates a potentially hazardous situation or an unintended use which, if not avoided, may result in minor or moderate injury and/or appreciable material, financial and environmental damage.
	Important paragraphs which must be adhered to in practice as they enable the product to be used in a technically correct and efficient manner.



Trademarks



- Windows is a registered trademark of Microsoft Corporation in the United States and other countries
 - Bluetooth is a registered trademark of Bluetooth SIG, Inc.
 - SD is a trademark of the SD Card Association
- All other trademarks are the property of their respective owners.



Validity of this manual

This manual applies to the GS10/GS15.

Available documentation

Name	Description/Format		
GS10/GS15 Quick Guide	Provides an overview of the product together with technical data and safety directions. Intended as a quick reference guide.	✓	✓
GS10/GS15 User Manual	All instructions required in order to operate the product to a basic level are contained in the User Manual. Provides an overview of the product together with technical data and safety directions.	-	✓

Name	Description/Format		
Viva GNSS Getting Started Guide	Describes the general working of the product in standard use. Intended as a quick reference field guide.	-	✓
Viva TPS Getting Started Guide	Describes the general working of the product in standard use. Intended as a quick reference field guide.	-	✓

Name	Description/Format		
Viva Series Technical Reference Manual	Overall comprehensive guide to the product and application functions. Included are detailed descriptions of special software/hardware settings and software/hardware functions intended for technical specialists.	-	✓

Refer to the following resources for all GS10/GS15 documentation/software:

- the Leica Viva Series DVD
- <https://myworld.leica-geosystems.com>



myWorld@Leica Geosystems (<https://myworld.leica-geosystems.com>) offers a wide range of services, information and training material.

With direct access to myWorld, you are able to access all relevant services whenever it is convenient for you, 24 hours a day, 7 days per week. This increases your efficiency and keeps you and your equipment instantly updated with the latest information from Leica Geosystems.

Service	Description
myProducts	Simply add all Leica Geosystems products that you and your company own. View detailed information on your products, buy additional options or Customer Care Packages (CCPs), update your products with the latest software and keep up-to-date with the latest documentation.
myService	View the service history of your products in Leica Geosystems Service Centers and detailed information on the services performed on your products. For your products that are currently in Leica Geosystems Service Centers view the current service status and the expected end date of service.
mySupport	Create new support requests for your products that will be answered by your local Leica Geosystems Support Team. View the complete history of your Support and view detailed information on each request in case you want to refer to previous support requests.
myTraining	Enhance your product knowledge with the Leica Geosystems Campus - Information, Knowledge, Training. Study the latest online training material or download training material on your products. Keep up-to-date with the latest News on your products and register for Seminars or Courses in your country.

Table of Contents

In this manual	Chapter	Page
	1 Description of the System	11
	1.1 System Components	11
	1.2 System Concept	13
	1.2.1 Software Concept	13
	1.2.2 Power Concept	15
	1.2.3 Data Storage Concept	17
	1.3 Instrument Components	18
	2 User Interface	20
	2.1 Keyboard	20
	2.2 Operating Principles	26
	3 Operation	27
	3.1 Equipment Setup	27
	3.1.1 Connecting to a Personal Computer	27
	3.1.2 Connecting to the Web Server	33
	3.1.3 Configuring the Instrument	37
	3.2 Batteries	39

3.2.1	Operating Principles	39
3.2.2	Battery for GS10	40
3.2.3	Battery for GS15	42
3.3	Working with the Memory Device	44
3.4	Working with the RTK Device	48
3.4.1	GS10	48
3.4.2	GS15	57
3.5	LED Indicators on GS10/GS15	64
3.6	Guidelines for Correct Results with GNSS Surveys	69
4	Care and Transport	70
<hr/>		
4.1	Transport	70
4.2	Storage	71
4.3	Cleaning and Drying	72
5	Safety Directions	73
<hr/>		
5.1	General Introduction	73
5.2	Intended Use	74
5.3	Limits of Use	76
5.4	Responsibilities	77
5.5	Hazards of Use	79

5.6	Electromagnetic Compatibility EMC	88
5.7	FCC Statement, Applicable in U.S.	91
6	Technical Data	95
6.1	GS10/GS15 Technical Data	95
6.1.1	Tracking Characteristics	95
6.1.2	Accuracy	98
6.1.3	Technical Data	100
6.2	Antennas Technical Data	106
6.3	Conformity to National Regulations	111
6.3.1	GS10	111
6.3.2	GS15	114
6.3.3	GFU24, Siemens MC75	116
6.3.4	GFU19 (US), GFU25 (CAN) CDMA MultiTech MTMMC-C	118
6.3.5	GFU28, Telit UC864-G	120
6.3.6	SLR1, SLR2, SATEL SATELLINE-3AS	122
6.3.7	SLR5, SATEL SATELLINE M3-TR1	124
6.3.8	SLR3-1, SLR3-2, Pacific Crest ADL	126
6.3.9	SLG1, Telit UC864-G	128
6.3.10	SLG2, CINTERION MC75i	130
6.3.11	SLC1 (US), SLC2 (US) CDMA Telit CC864-DUAL	132

7	International Limited Warranty, Software Licence Agreement	134
<hr/>		
Appendix A	Pin Assignments and Sockets	136
<hr/>		
A.1	GS10	136
A.2	GS15	140
<hr/>		
Index		144
<hr/>		

1 Description of the System

1.1 System Components

Main components

Component	Description
Instrument	To calculate a position from the computed ranges to all visible GNSS (Global Navigation Satellite System) satellites.
Web server	Web-based tool to preprogram the GNSS instrument.
Antenna	To receive the satellite signals from the GNSS satellites.
LEICA Geo Office	The office software including a series of help programs which support working with Leica Viva Series instruments.

Instruments

Depending on the satellite systems and signals configured, a maximum number of 120 channels is allocated.

Instrument	Description
GS10	Up to 16 L1, 16 L2, 16 L5 channels (GPS), up to 14 L1, 14 L2 channels (GLONASS), up to 14 E1, 14 E5a, 14 E5b, 14 Alt-BOC channels (Galileo), four channels SBAS (EGNOS, WAAS, MSAS, GAGAN), code and phase, real-time capable

Instrument	Description
GS15	Up to 16 L1, 16 L2, 16 L5 channels (GPS), up to 14 L1, 14 L2 channels (GLONASS), up to 14 E1, 14 E5a, 14 E5b, 14 Alt-BOC channels (Galileo), four channels SBAS (EGNOS, WAAS, MSAS, GAGAN), code and phase, real-time capable



Once the first operational Galileo satellites are available, a software update will be required.



The GS GNSS instruments are additionally designed to support Compass. The Compass signal definition is not fully finalised, although, test signals have been tracked in a test environment. As changes can still occur, Leica Geosystems cannot guarantee full Compass compatibility.

1.2

System Concept

1.2.1

Software Concept

Description

All instruments use the same software concept.

Software for all GS GNSS instruments

Software type	Description
GS firmware (GS_xx.fw)	<p>This important software covers all functions of the instrument.</p> <p>The Web server application is integrated into the firmware and cannot be deleted.</p> <p>The English language is integrated into the firmware and cannot be deleted.</p>
Language software (WEB_LANG.sxx)	<p>Numerous languages are available for the Web server application.</p> <p>The English language is the default language. One language is chosen as the active language.</p>

Software upload

Uploading GS firmware can take some time. Ensure that the battery is at least 75% full before beginning the upload, and do not remove the battery during the upload process.

Software for	Description
All GS models	<p>The software can be uploaded using the Leica Web server application or myWorld@Leica Geosystems.</p> <p> Ensure that a Leica SD card is inserted into the GS instrument before starting the upload. Refer to "3.3 Working with the Memory Device".</p>

1.2.2

Power Concept

General

Use the Leica Geosystems batteries, chargers and accessories or accessories recommended by Leica Geosystems to ensure the correct functionality of the instrument.

Power options

Power for the instrument can be supplied either internally or externally. Up to two external power supplies can be connected.

Internal power supply:

Two batteries (for GS10: GEB221 or GEB222; for GS15: GEB211 or GEB212) fit into the instrument.



If one battery fails, a system shutdown of the GS10/GS15 GNSS instrument will be prevented by switching over directly to the second battery.

External power supply:

GEB171 battery connected via a cable.

OR

Car battery connected via a converter cable supplied by Leica Geosystems.

OR

10.5 V-28 V DC power supply via a converter cable supplied by Leica Geosystems.

OR

110 V/240 V AC to 12 V DC power supply unit, supplied by Leica Geosystems.



For permanent operations use **U**ninterruptible **P**ower **S**upply units as a back-up in a main power failure.

1.2.3

Data Storage Concept

Description

Data (Leica GNSS raw data and RINEX data) can be recorded on the SD card.

Memory device

SD card: All GS GNSS instruments have an SD card slot fitted as standard. An SD card can be inserted and removed. Available capacity: 1 GB.



While other SD cards can be used, Leica Geosystems recommends to only use Leica SD cards and is not responsible for data loss or any other error that can occur while using a non-Leica card.



Unplugging connecting cables or removing the SD card during the measurement can cause loss of data. Only remove the SD card or unplug connecting cables when the GS GNSS instrument is switched off.



SD cards can directly be used in an OMNI drive as supplied by Leica Geosystems. Other PC card drives can require an adaptor.

1.3 Instrument Components



The instrument can be preprogrammed using the Web server application running from the instrument on a web browser of a Windows device. In this case, the instrument is turned on by holding down the ON/OFF button for 2 s or off by holding down the ON/OFF button for 2 s. A green steady light at the power LED indicates that the instrument is turned on.

GS10 components

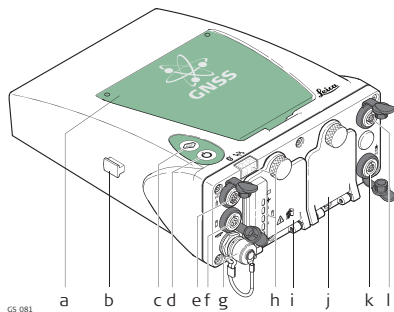

GS_081

- a) Bluetooth antenna
- b) Guide rail for clip-on-housing of a device (available on both sides)
- c) Function button
- d) ON/OFF button
- e) LEMO port P3
- f) Power port
- g) Antenna port
- h) LED indicators
- i) Battery compartment A including SD card compartment
- j) Battery compartment B
- k) LEMO port P2
- l) LEMO port P1 including USB port

GS15 components

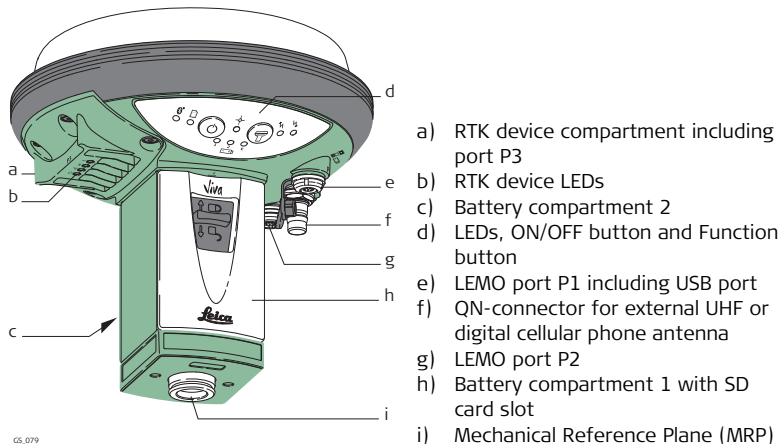

A Bluetooth port is included inside all GS GNSS instruments to enable connectivity to the CS10/CS15 field controller.

2 User Interface

2.1 Keyboard

Keyboard GS10

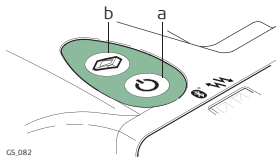

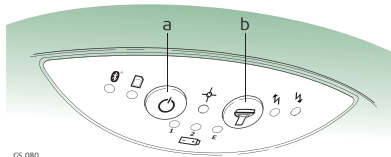

- a) ON/OFF button
- b) Function button

Keyboard GS15





- a) ON/OFF button
 - b) Function button
-

ON/OFF button

Button	Function
ON/OFF 	<p>If GS10/GS15 already off: Turns on GS10/GS15 when held for 2 s.  While the GS10/GS15 is booting all three battery LEDs are lighted. Once the GS10/GS15 has started, the normal LED behaviour starts.</p> <p>If GS10/GS15 already on: Turns off GS10/GS15 when held for 2 s.  All LEDs will shine red for 1 s-2 s and then are turned off.</p>

Function button

 All functions following described assume the GS10/GS15 is already on.



Button	Function
Function 	<p>Press and hold button for < 1 s.</p> <p>If the GS10/GS15 is in:</p> <ul style="list-style-type: none">base mode: The GS10/GS15 switches to be in rover mode.

Button	Function
	<ul style="list-style-type: none">• rover mode and in static mode: The GS10/GS15 switches to be in base mode.• rover mode and in kinematic mode: The GS10/GS15 switches to be in base mode. <p>Press and hold button for 3 s.</p> <p>If the GS10/GS15 is in:</p> <ul style="list-style-type: none">• base mode and a position is available: The RTK base LED flashes green for 2 s. The GS10/GS15 takes the next available position and updates the coordinates of the currently stored RTK base position.• base mode and no position is available: The RTK base LED flashes yellow for 2 s.• rover mode: No action. <p>Press and hold button for 5 s.</p> <p>If the GS10/GS15 is in:</p> <ul style="list-style-type: none">• base mode: No action.

Button	Function
	<ul style="list-style-type: none"> • rover mode and in static mode: The GS10/GS15 switches to be in base mode. • rover mode and in kinematic mode: The GS10/GS15 switches to be in base mode. <hr/> <p>Press and hold button for 3 s.</p> <p>If the GS10/GS15 is in:</p> <ul style="list-style-type: none"> • base mode and a position is available: The RTK base LED flashes green for 2 s. The GS10/GS15 takes the next available position and updates the coordinates of the currently stored RTK base position. • base mode and no position is available: The RTK base LED flashes yellow for 2 s. • rover mode: No action. <hr/> <p>Press and hold button for 5 s.</p> <p>If the GS10/GS15 is in:</p> <ul style="list-style-type: none"> • base mode: No action.

Button	Function
	<ul style="list-style-type: none"> rover mode and configured for a dial-up or Ntrip connection: The RTK rover LED flashes green for 2 s. The GS10/GS15 will connect to the RTK base station or the Ntrip server configured. rover mode and not configured for a dial-up or Ntrip connection: No action.

Button combinations

Button	Function
ON/OFF 	Press and hold buttons for 1 s.
Function 	<p>The current almanacs stored on the GNSS instrument are deleted and new almanacs are downloaded. The Position LED flashes red quickly three times.</p> <p>Press and hold buttons for 5 s.</p> <p>The Memory LED flashes red quickly three times. The SD card of the GNSS instrument is formatted. The Memory LED continues to flash red as the SD card is formatted.</p> <p>Press and hold buttons for 10 s.</p>

Button	Function
	<p>The System RAM on the GNSS instrument is formatted. Settings of all installed software will be deleted. All LEDs (except Battery LED and Bluetooth LED) flash red quickly three times. After the formatting the System RAM, the GNSS instrument is turned off.</p> <hr/> <p>Press and hold buttons for 15 s.</p> <p>The registry of the GNSS instrument is deleted. Windows CE and communication settings will be reset to factory defaults. All LEDs (except Battery LED and Bluetooth LED) flash red quickly three times. After deleting the registry, the GNSS instrument is turned off.</p>

2.2 Operating Principles

Operating the instrument

The GS10/GS15 GNSS instrument is operated either by the pressing its buttons (ON/OFF button, function button) or by the CS field controller.

Operation by buttons

The GS10/GS15 GNSS instrument is operated by pressing its buttons. Refer to "2.1 Keyboard" for a detailed description of the buttons and their function.

Operation by CS field controller

The GS10/GS15 GNSS instrument is operated by the CS field controller using the SmartWorx Viva software. Refer to the Leica CS10/CS15 User Manual or Leica Viva GNSS Getting Started Guide for a detailed description of the keys and their function.

Turn on GS10/GS15

To turn on the instrument press and hold the Power button for 2 s.

Turn off GS10/GS15

To turn off the instrument:

- press and hold the ON/OFF button for 2 s
 - confirm to power down the instrument when exiting SmartWorx Viva software on the CS10/CS15 field controller
-

3

3.1

3.1.1



Install Leica Viva USB drivers



Operation

Equipment Setup

Connecting to a Personal Computer

Microsoft ActiveSync (for PCs with Windows XP operating system) or Windows Mobile Device Center (for PCs with Windows Vista or Windows 7 operating system) is the synchronisation software for Windows mobile-based pocket PCs. Microsoft ActiveSync or Windows Mobile Device Center enables a PC and a Windows mobile-based pocket PC to communicate.

Step	Description
1.	Start the PC.
2.	Insert the Leica Viva Series DVD.

Step	Description
3.	<p>Run the SetupViva&GR_USB_XX.exe to install the drivers necessary for Leica Viva devices. Depending on the version (32bit or 64bit) of the operating system on your PC, you have to select between the three setup files following:</p> <ul style="list-style-type: none">• SetupViva&GR_USB_32bit.exe• SetupViva&GR_USB_64bit.exe• SetupViva&GR_USB_64bit_itanium.exe <p> The setup has to be run only once for all Leica Viva devices.</p>
4.	<p>The Welcome to InstallShield Wizard for Leica Viva & GR USB drivers window appears.</p> <p> Ensure that all Leica Viva devices are disconnected from your PC before you continue!</p>
5.	Next>.
6.	The Ready to Install the Program window appears.
7.	<p>Install. The drivers will be installed on your PC.</p> <p> For PCs with Windows Vista or Windows 7 operating system: If not already installed, Windows Mobile Device Center will be installed additionally.</p>
8.	The InstallShield Wizard Completed window appears.

Step	Description
9.	Check I have read the instructions and click Finish to exit the wizard.

Connect USB cable to PC for the first time step-by-step

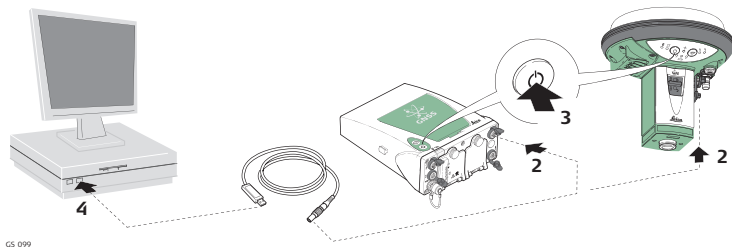

GS_099

Step	Description
1.	Start the PC.
2.	Plug the GEV234 cable into Port P1 of the instrument (GS10/GS15).
3.	Turn on the instrument.
4.	Plug the GEV234 cable into the USB port of the PC. The Found New Hardware Wizard starts up automatically.
5.	Check Yes, this time only. Next> .

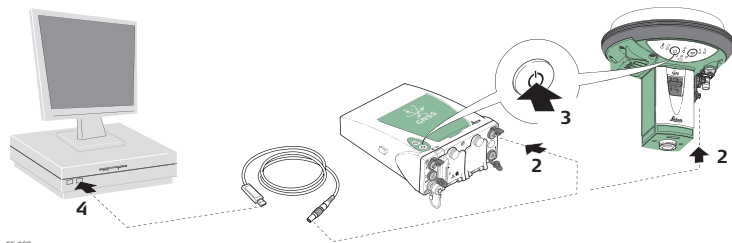

Step	Description
6.	Check Install the software automatically (Recommended). Next> . The software for Remote NDIS based LGS GS Device will be installed on your PC.
7.	Finish.
8.	The Found New Hardware Wizard starts up automatically a second time.
9.	Check Yes, this time only. Next> .
10.	Check Install the software automatically (Recommended). Next> . The software for LGS GS USB Device will be installed on your PC.
11.	Finish.
	For PCs with Windows XP operating system:
12.	Run the ActiveSync installation program if not already installed.
13.	Allow USB connections inside the Connection Settings window of Active-Sync.
	For PCs with Windows Vista or Windows 7 operating system:
14.	Windows Mobile Device Center starts up automatically. If does not start automatically, start Windows Mobile Device Center.

Connect to PC via USB cable step-by- step



GS.099

Step	Description
1.	Start the PC.
2.	Plug the GEV234 cable into port P1 of the instrument (GS10/GS15).
3.	Turn on the instrument.
4.	Plug the GEV234 cable into the USB port of the PC.
	For PCs with Windows XP operating system:
	 ActiveSync starts up automatically. If does not start automatically, start ActiveSync. If not already installed, run the ActiveSync installation program.

Step	Description
5.	Allow USB connections inside the Connection Settings window of ActiveSync.
6.	Click Explore in ActiveSync.  The folders on the CS field controller are displayed under Mobile Devices . The folders of the data storage device can be found in StorageCard .
	For PCs with Windows Vista or Windows 7 operating system:  Windows Mobile Device Center starts up automatically. If does not start automatically, start Windows Mobile Device Center.

3.1.2

Connecting to the Web Server

Description

The Web server is a web-based tool to view the status of and configure the GNSS instruments. The Web server application is integrated into the GS firmware and cannot be deleted.

Accessing the Web server via cable step-by-step

Step	Description
1.	Start the PC and turn on the GS GNSS instrument.  Instead of connecting to your PC, you can connect your GS GNSS instrument to the Leica CS field controller.
2.	Connect the GS GNSS instrument with the GEV234 cable to the PC. Refer to "3.1.1 Connecting to a Personal Computer".
3.	Double-Click the Configure GS connection shortcut from the desktop of your PC. The GS GNSS network adapter is configured with IP address: 192.168.254.1. A DOS window appears when the configuration was successful. Press any key to exit the DOS window. The Configure GS connection shortcut disappears from the desktop.
4.	Start the web browser of your PC.
5.	Type in http://192.168.254.2 and press enter to access the web server of GS instrument.

Accessing the Web server via Bluetooth step-by-step



To access the Web server the tasks following have to be done:

- Configure the PC's Bluetooth device
- Establish a Bluetooth connection between PC and GS
- Accessing the Web server

Configuring the PC's Bluetooth device

Step	Description
1.	Start your PC.
2.	Activate the Bluetooth device of your PC.
3.	Go Start ⇒ Settings ⇒ Network Connections .
4.	Double-click Bluetooth from the LAN or High-Speed Internet device list. The Bluetooth Properties windows is started.
5.	In the General page, select Internet Protocol (TCP/IP) from the list and click Properties . The Internet Protocol (TCP/IP) properties windows is started.
6.	Set IP address: 192.168.253.1 and Subnet mask: 255.255.255.0 and click OK confirm the settings.
	This procedure has to be done only once.

Establishing a Bluetooth connection between PC and GS GNSS instrument

Step	Description
1.	<p>Start the PC and turn on the GS GNSS instrument.</p> <p> Instead of connecting to your PC, you can connect your GS GNSS instrument to the Leica CS field controller. In this case, turn on the Leica CS field controller, start SmartWorx Viva and establish a Bluetooth connection to the GS GNSS instrument.</p>
2.	Run the Bluetooth software and start the Bluetooth Setup Wizard .
3.	Click Next . The Bluetooth Device Selection will be started and an automatic search will be done.
4.	Select the shown GS GNSS instrument and click Next . The Bluetooth Security Setup is started.
5.	Type in 0000 as Bluetooth security code and click Pair Now . The pairing procedure will be done and the Bluetooth Service Selection is started.
6.	<p>Highlight Personal Ad-hoc Network and check the checkbox for Personal Ad-hoc Network.</p> <p> Do not select Serial Port as service.</p>
7.	Click Next . The Bluetooth Setup Wizard Completion Page is started.
8.	Type in a name for your GS GNSS instrument and click Finish to complete the Bluetooth Setup Wizard .

Step	Description
	This procedure has to be repeated for every GS GNSS instrument you want to connect to.

Accessing the Web server

Step	Description
1.	<p>Start the web browser on your PC/CS field controller.</p> <p> Ensure that your GS GNSS instrument is still running and the Bluetooth connection between PC /CS field controller and GS is established.</p>
2.	<p>Type in 192.168.253.2. The Web server is started. You will see the home functions following:</p> <ul style="list-style-type: none">• Go to Work!<ul style="list-style-type: none">- To select and start the Wake-up application.• Current Status<ul style="list-style-type: none">- To access GNSS information of the GS as well as the instrument firmware.• Instrument<ul style="list-style-type: none">- To access configuration settings for the GS.• User<ul style="list-style-type: none">- To upload and activate firmware, licence keys and languages.

3.1.3

Configuring the Instrument

Description

The instrument can be set up as real-time rover or as real-time base by pressing the function button.



Turn on the instrument before pressing the function button. Refer to "Turn on GS10/GS15".

Switching to a real-time rover

Function button	IF the	is	THEN
Press and hold button for < 1 s	GS	in base mode	The GS GNSS instrument switches to be in rover mode.

Switching to a real-time base

Function button	IF the	is	THEN
Pressing for < 1 s	GS	in rover mode and in static mode	The GS GNSS instrument switches to be in base mode and takes the most recent computed position (the average of all static positions).

Function button	IF the	is	THEN
		in rover mode and in kinematic mode	The GS GNSS instrument switches to be in base mode.

Updating RTK base position

Function button	IF the	is	THEN
Press and hold button for 3 s	GS	in base mode and a position is available	The RTK base LED flashes green for 2 s. The GS GNSS instrument takes the next available position and updates the coordinates of the currently stored RTK base position.
		in base mode and no position is available	The RTK base LED flashes yellow for 2 s.
		in rover mode	No action.  The GS has to be switched to base mode first. Refer to "Switching to a real-time base".

3.2

3.2.1

Batteries

Operating Principles

Charging / first-time use

- The battery must be charged prior to using it for the first time because it is delivered with an energy content as low as possible.
 - The permissible temperature range for charging is between 0°C to +40°C/ +32°F to +104°F. For optimal charging, we recommend charging the batteries at a low ambient temperature of +10°C to +20°C/+50°F to +68°F if possible.
 - It is normal for the battery to become warm during charging. Using the chargers recommended by Leica Geosystems, it is not possible to charge the battery if the temperature is too high.
 - For new batteries or batteries that have been stored for a long time (> three months), it is effectual to make only one charge/discharge cycle.
 - For Li-Ion batteries, a single discharging and charging cycle is sufficient. We recommend carrying out the process when the battery capacity indicated on the charger or on a Leica Geosystems product deviates significantly from the actual battery capacity available.
-

Operation / Discharging

- The batteries can be operated from -20°C to +55°C/-4°F to +131°F.
 - Low operating temperatures reduce the capacity that can be drawn; high operating temperatures reduce the service life of the battery.
-

3.2.2

Battery for GS10

Change battery
step-by-step

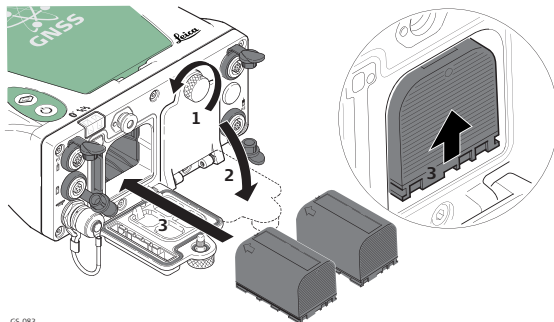

GS_083

Step	Description
	The batteries are inserted in the front of the instrument.
1.	Loosen the screw of one of the battery compartments.
2.	Open the cover of the battery compartment.
3.	With the Leica logo facing upwards, slide the battery into the battery compartment and push upwards so that it locks into position.

Step	Description
4.	Close the cover of the battery compartment and tighten the screw.
5.	Repeat steps 1. to 4. for the second battery compartment.
6.	To remove a battery, loosen the screw to open the cover of the battery compartment.
7.	Push the battery slightly in and at the same time downwards. This releases the battery from its fixed position.
8.	Pull out the battery.
9.	Close the cover of the battery compartment and tighten the screw.
10.	Repeat steps 6. to 9. for the second battery compartment.

3.2.3

Battery for GS15

Change battery
step-by-step

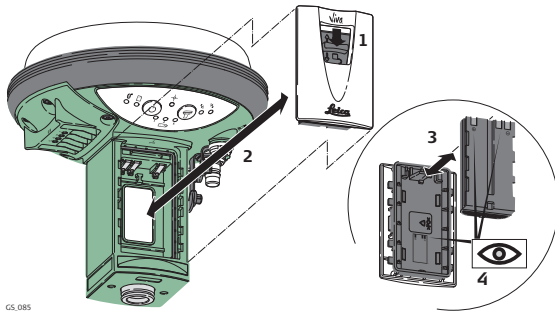

GS_085

Step	Description
	The batteries are inserted in the bottom part of the instrument.
1.	Push the slide fastener of one of the battery compartments in the direction of the arrow with the open-lock symbol.
2.	Remove the cover from the battery compartment.

Step	Description
3.	With the battery contacts facing upwards, slide the battery into the cover of the battery compartment.
4.	Push the battery upwards so that it locks into position.
5.	Insert the cover of the battery compartment into the compartment and push the slide fastener in the direction of the arrow with the close-lock symbol.
6.	Repeat steps 1. to 5. for the second battery compartment.
7.	To remove a battery, push the slide fastener of one of the battery compartments in the direction of the arrow with the open-lock symbol and remove the cover.
8.	Push the battery slightly upwards and at the same time pull out the bottom part of the battery. This releases the battery from its fixed position.
9.	Remove the battery.
10.	Insert the cover into the battery compartment and push the slide fastener in the direction of the arrow with the close-lock symbol.
11.	Repeat steps 7. to 10. for the second battery compartment.

3.3 Working with the Memory Device





- Keep the card dry.
- Use it only within the specified temperature range.
- Do not bend the card.
- Protect the card from direct impacts.

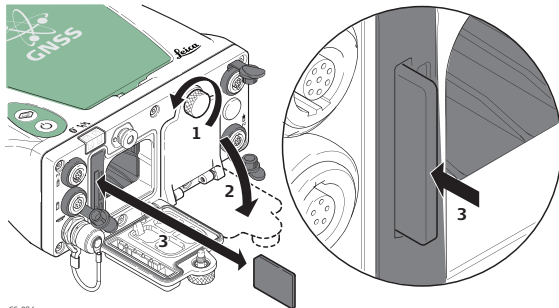

Failure to follow these instructions could result in data loss and/or permanent damage to the card.

**Insert and remove
an SD card into
GS10 step-by-step**



Step	Description
	The SD card is inserted into a slot inside the battery compartment A of the instrument.
1.	Open the cover of battery compartment A. Refer to "3.2.2 Battery for GS10" for further information.
2.	Insert the card firmly into the slot until it clicks into position.
3.	Close the cover of battery compartment A and tighten the screw.
4.	To remove the card, open the cover of battery compartment A.
5.	Gently press on the top of the card to release it from the slot.
6.	Remove the SD card.
7.	Close the cover of battery compartment A and tighten the screw.

Insert and remove an SD card into GS15 step-by-step

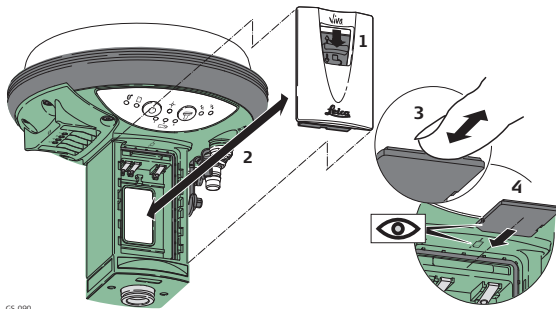

GS_090

Step	Description
	The SD card is inserted into a slot inside the battery compartment 1 of the instrument.
1.	Push the slide fastener of battery compartment 1 in the direction of the arrow with the open-lock symbol.
2.	Remove the cover from battery compartment 1.
3.	Slide the card firmly into the slot until it clicks into position.

Step	Description
4.	Do not force the card into the slot. The card should be held with the contacts upwards and facing the slot.
5.	To remove the card, push the slide fastener of battery compartment 1 in the direction of the arrow with the open-lock symbol and remove the cover.
6.	Gently press on the top of the card to release it from the slot.
7.	Remove the SD card.
8.	Insert the cover into battery compartment 1 and push the slide fastener in the direction of the arrow with the close-lock symbol.

3.4 Working with the RTK Device

3.4.1 GS10

Devices fitting into a clip-on-housing

Digital cellular phones fitting into a clip-on-housing

Digital cellular phone	Clip-on-housing
Siemens MC75	GFU24
CDMA MultiTech MTMMC-C (US)	GFU19
CDMA MultiTech MTMMC-C (CAN)	GFU25
Telit UC864-G	GFU28

Radios fitting into a clip-on-housing

Radio	Clip-on-housing
Pacific Crest PDL, receive	GFU15
Satellite 3AS, transceiver	GFU14
Satellite M3-TR1, transceiver	GFU27

Attach and detach a clip-on-housing step-by-step

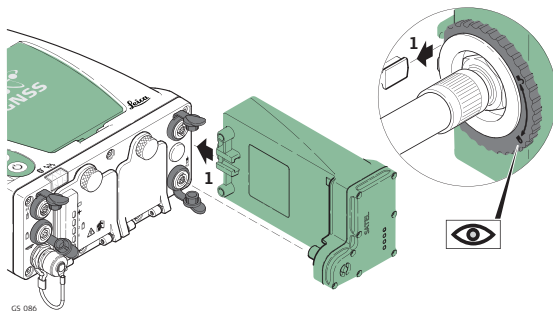



GS_086

Step	Description
	The clip-on-housing for devices fits on either of the small sides of the instrument.
1.	Place the clip-on-housing into position such that the guide rails for the clip-on-housing on the instrument and the guide rails on the clip-on-housing are aligned.
2.	Ensure that the connector on the clip-on-housing fits to port P2 or port P3 on the instrument front panel.

Step	Description
3.	Slide the clip-on-housing toward the instrument front panel until the connector is plugged into port P2 or port P3.
4.	On the top side of the clip-on-housing, turn the screw clockwise, as shown by the symbols on the screw, to lock the clip-on-housing to the instrument.
5.	To detach the clip-on-housing, turn the screw anticlockwise on the top side of the clip-on-housing, as shown by the symbols on the screw, to unlock the clip-on-housing from the instrument.
6.	Slide the clip-on-housing away from the instrument front panel until the connector is unplugged from port P2 or port P3.

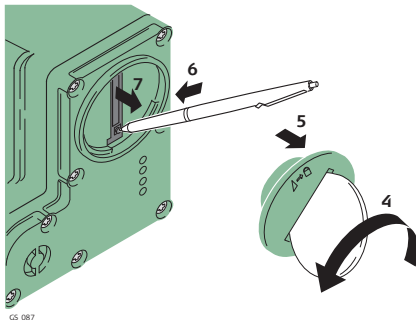
Insert and remove a SIM card step-by-step



Step	Description
	The SIM card is inserted into a slot on the bottom of the clip-on-housing.
1.	Take the SIM card, a coin and a pen.
2.	Locate the SIM card screw, that covers the SIM card slot, on the bottom of the clip-on-housing.
3.	Insert the coin into the groove of the SIM card screw.
4.	Turn the coin anticlockwise to loosen the SIM card screw.
5.	Remove the SIM card screw from the housing.

Step	Description
6.	Using the pen, press the small button of the SIM card slot to eject the SIM card holder.
7.	Take the SIM card holder out off the housing.
8.	Place the SIM card into the SIM card holder, the chip facing up.
9.	Insert the SIM card holder into the SIM card slot, the chip facing the connectors inside the slot.
10.	Place the SIM card screw back on the housing.
11.	Insert the coin into the groove of the SIM card screw.
12.	Turn the coin clockwise to tighten the SIM card screw.

LED indicators

Description

Each clip-on-housing for a radio or digital cellular phones has **Light Emitting Diode** indicators on the bottom side. They indicate the basic device status.

Diagram

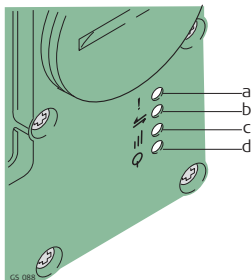

- a) Mode LED, available for Satelline 3AS
- b) Data transfer LED
- c) Signal strength LED
- d) Power LED

Description of the LEDs

IF the	on	is	THEN
Mode LED	GFU14 with Satelline 3AS, GFU27 with Satelline M3-TR1	red	the device is in the programming mode controlled from the PC via cable.

IF the	on	is	THEN
Data transfer LED	any device	off	data is not being transferred.
		green or flashing green	data is being transferred.
Signal strength LED	GFU19 (US), GFU25 (CAN) with CDMA Multi-Tech MTMMC-C	red	device is on, not registered on the network.
		flashing red	device is on, registered on the network.
		off	download mode or device is off.

IF the	on	is	THEN
	GFU24 with Siemens MC75, GFU28 with Telit UC864-G	red	call is in progress.
		red: long flash, long break	no SIM card inserted, no PIN entered or network search, user authentication or network login in progress.
		red: short flash, long break	logged on to network, no call in progress.
		red: flashing red, long break	GPRS PDP context activated.
		red: long flash, short break	Packet switched data transfer is in progress.
		off	device is off.
	GFU15 with Pacific Crest PDL	red or flashing red	the communication link, Data Carrier Detection , is okay on the roving instrument.
		off	the DCD is not okay.

IF the	on	is	THEN
	GFU14 with Satellite 3AS, GFU27 with Satellite M3-TR1	red or flashing red	the communication link, Data Carrier Detection , is okay on the roving instrument.
		off	the DCD is not okay.
Power LED	any device	off	power is off.
		green	power is okay.

3.4.2

GS15

Devices fitting into the GS15 GNSS instrument

Digital cellular phones fitting into the GS15 GNSS instrument

Digital cellular phone	Device
Telit UC864-G	SLG1
CINTERION MC75i	SLG2
CDMA Telit CC864-DUAL (US)	SLC1, SLC2

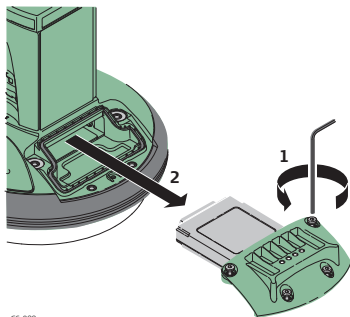

Radios fitting into the GS15 GNSS instrument

Radio	Device
Pacific Crest PDL, transceive	SLR3-1
Pacific Crest PDL, transceive	SLR3-2
Satellite 3AS, transmit	SLR1
Satellite 3AS, receive	SLR2
Satellite M3-TR1, transceive	SLR5

**Insert and remove
a slot-in-device
step-by-step**



GS_089

Step	Description
	Turn over the GS15 to gain access to the slot-in-device compartment.
1.	Loosen the screws of the compartment cover with the supplied Allen key.
2.	Remove the compartment cover.
3.	Attach the slot-in-device to the compartment cover.
4.	Insert the compartment cover into the compartment (port P3).

Step	Description
5.	Tighten the screws.  All screws have to be tightened to ensure that the instrument is waterproof.
	For the equipment setup as real-time base station with radio, it's recommended to use an external radio antenna mounted on a second tripod. This increases the height of the radio antenna and therefore maximises radio coverage. Refer to the Leica Viva GNSS Getting Started Guide for detailed information about the setup.

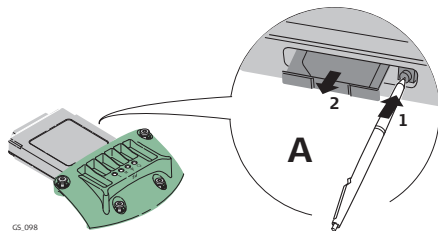
Insert and remove a SIM card step-by-step



Step	Description
	The SIM card is inserted into a slot on the side of the SLG1/SLG2.
	Take the SIM card and a pen.
1.	Using the pen, press the small button of the SIM card slot to eject the SIM card holder.
2.	Take the SIM card holder out off the SLG1/SLG2.
3.	Place the SIM card into the SIM card holder, the chip facing up.
4.	Insert the SIM card holder into the SIM card slot, the chip facing the connectors inside the slot.

LED indicators

Description

Each slot-in-device for a radio or digital cellular phones has **L**ight **E**mitting **D**iode indicators on the bottom side. They indicate the basic device status.

Diagram

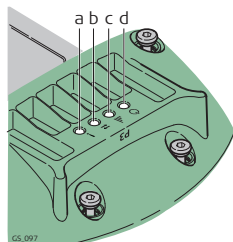

- a) Mode LED, available for Sateline 3AS
- b) Data transfer LED
- c) Signal strength LED
- d) Power LED

Description of the LEDs

IF the	on	is	THEN
Mode LED	SLR1, SLR2 with Sateline 3AS, SLR5 with Sateline M3-TR1	red	the device is in the programming mode controlled from the PC via cable.
Data transfer LED	any device	off	data is not being transferred.
		flashing green	data is being transferred.

IF the	on	is	THEN
Signal strength LED	SLC1 (US), SLC2 (US) with CDMA Telit CC864-DUAL	red	device is on, not registered on the network.
		flashing red	device is on, registered on the network.
		off	download mode or device is off.
	SLG1 with Telit UC864-G, SLG2 with CINTERION MC75i	red	call is in progress.
		red: long flash, long break	no SIM card inserted, no PIN entered or network search, user authentication or network login in progress.
		red: short flash, long break	logged on to network, no call in progress.
		red: flashing red, long break	GPRS PDP context activated.
		red: long flash, short break	Packet switched data transfer is in progress.
		off	device is off.

IF the	on	is	THEN
	SLR3-1, SLR3-2 with Pacific Crest ADL	red	the communication link, Data Carrier Detection , is okay on the roving instrument.
		flashing red	the communication link, Data Carrier Detection , is okay on the roving instrument, but signal is weak.
		off	the DCD is not okay.
	SLR1, SLR2 with Sateline 3AS, SLR5 with Sateline M3-TR1	red	the communication link, Data Carrier Detection , is okay on the roving instrument.
		flashing red	the communication link, Data Carrier Detection , is okay on the roving instrument, but signal is weak.
		off	the DCD is not okay.
Power LED	any device	off	power is off.
		green	power is okay.

3.5 LED Indicators on GS10/GS15

LED indicators

Description

The GS10/GS15 GNSS instrument has Light Emitting Diode indicators. They indicate the basic instrument status.

Diagram

GS10

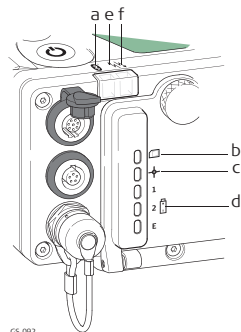

GS15

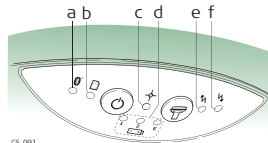

- a) Bluetooth LED
- b) Storage LED
- c) Position LED
- d) Power LEDs
- e) RTK Base LED
- f) RTK Rover LED

Description of the LEDs

IF the	is	THEN
Bluetooth LED	green	Bluetooth is in data mode and ready for connecting.
	purple	Bluetooth is connecting.
	blue	Bluetooth has connected.
Storage LED	off	no SD card is inserted or GS10/GS15 is switched off.
	green	SD card is inserted but no raw data is being logged.
	flashing green	raw data is being logged.
	flashing yellow	raw data is being logged but only 10% memory left.
	flashing red	raw data is being logged but only 5% memory left.
	red	SD card is full, no raw data is being logged.
	fast flashing red	no SD card is inserted but GS10/GS15 is configured to log raw data.
Position LED	off	no satellites are tracked or GS10/GS15 is switched off.

IF the	is	THEN
	flashing yellow	less than four satellites are tracked, a position is not yet available.
	yellow	a navigated position is available.
	flashing green	a code-only position is available.
	green	a fixed RTK position is available.
Power LED (active battery ^{*1})	off	battery is not connected, flat or GS10/GS15 is switched off.
	green	power is 40% - 100%.
	yellow	power is 20% - 40%. The remaining time for which enough power is available depends on the type of survey, the temperature and the age of the battery.
	red	power is 5% - 20%.
	fast flashing red	power is low (< 5%).
Power LED (passive battery ^{*2})	off	battery is not connected, flat or the GS10/GS15 is switched off.

IF the	is	THEN
	flashing green	power is 40% - 100%. LED is green for 1 s every 10 s.
	flashing yellow	power is 20% - 40%. LED is yellow for 1 s every 10 s.
	flashing red	power is less than 20%. LED is red for 1 s every 10 s.
RTK Rover LED	off	GS10/GS15 is in RTK base mode or GS10/GS15 is switched off.
	green	GS10/GS15 is in rover mode. No RTK data is being received at the interface of the communication device.
	flashing green	GS10/GS15 is in rover mode. RTK data is being received at the interface of the communication device.
RTK Base LED	off	GS10/GS15 is in RTK rover mode or GS10/GS15 is switched off.
	green	GS10/GS15 is in RTK base mode. No RTK data is being passed to the RX/TX interface of the communication device.

IF the	is	THEN
	flashing green	GS10/GS15 is in RTK base mode. Data is being passed to the RX/TX interface of the communication device.

*1 The battery, which currently powers the GS10/GS15 GNSS instrument.

*2 Other batteries, which are inserted or connected but are not currently power the GS10/GS15 GNSS instrument.

3.6

Guidelines for Correct Results with GNSS Surveys

Undisturbed satellite signal reception

Successful GNSS surveys require undisturbed satellite signal reception, especially at the instrument which serves as a base. Set up the instrument in locations which are free of obstructions such as trees, buildings or mountains.

Steady antenna for static surveys

For static surveys, the antenna must be kept perfectly steady throughout the whole occupation of a point. Place the antenna on a tripod or pillar.

Centred and levelled antenna

Centre and level the antenna precisely over the marker.

4 Care and Transport

4.1 Transport

Transport in the field

When transporting the equipment in the field, always make sure that you

- either carry the product in its original transport container,
 - or carry the tripod with its legs splayed across your shoulder, keeping the attached product upright.
-

Transport in a road vehicle

Never carry the product loose in a road vehicle, as it can be affected by shock and vibration. Always carry the product in its transport container and secure it.

Shipping

When transporting the product by rail, air or sea, always use the complete original Leica Geosystems packaging, transport container and cardboard box, or its equivalent, to protect against shock and vibration.

Shipping, transport of batteries

When transporting or shipping batteries, the person in charge of the product must ensure that the applicable national and international rules and regulations are observed. Before transportation or shipping, contact your local passenger or freight transport company.

4.2

Storage

Product

Respect the temperature limits when storing the equipment, particularly in summer if the equipment is inside a vehicle. Refer to "6 Technical Data" for information about temperature limits.

Li-Ion batteries

- Refer to "6 Technical Data" for information about storage temperature range.
 - At the recommended storage temperature range, batteries containing a 10% to 50% charge can be stored for up to one year. After this storage period the batteries must be recharged.
 - Remove batteries from the product and the charger before storing.
 - After storage recharge batteries before using.
 - Protect batteries from damp and wetness. Wet or damp batteries must be dried before storing or use.
 - A storage temperature range of -20°C to +30°C/-4°F to 86°F in a dry environment is recommended to minimise self-discharging of the battery.
-

4.3 Cleaning and Drying

Product and accessories

- Use only a clean, soft, lint-free cloth for cleaning. If necessary, moisten the cloth with water or pure alcohol. Do not use other liquids; these may attack the polymer components.
-

Damp products

Dry the product, the transport container, the foam inserts and the accessories at a temperature not greater than 40°C/104°F and clean them. Do not repack until everything is dry. Always close the transport container when using in the field.

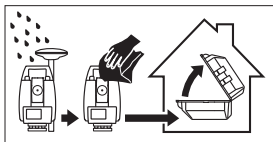

Cables and plugs

Keep plugs clean and dry. Blow away any dirt lodged in the plugs of the connecting cables.

Connectors with dust caps

Wet connectors must be dry before attaching the dust cap.

5

Safety Directions

5.1

General Introduction

Description

The following directions enable the person responsible for the product, and the person who actually uses the equipment, to anticipate and avoid operational hazards.

The person responsible for the product must ensure that all users understand these directions and adhere to them.

5.2

Intended Use

Permitted use

- Computing with software.
 - Carrying out measurement tasks using various GNSS measuring techniques.
 - Recording GNSS and point related data.
 - Data communication with external appliances.
 - Measuring raw data and computing coordinates using carrier phase and code signal from GNSS satellites.
-

Adverse use

- Use of the product without instruction.
- Use outside of the intended limits.
- Disabling safety systems.
- Removal of hazard notices.
- Opening the product using tools, for example screwdriver, unless this is permitted for certain functions.
- Modification or conversion of the product.
- Use after misappropriation.
- Use of products with recognisable damages or defects.
- Use with accessories from other manufacturers without the prior explicit approval of Leica Geosystems.
- Inadequate safeguards at the working site, for example when measuring on roads.
- Controlling of machines, moving objects or similar monitoring application without additional control- and safety installations.



WARNING

Adverse use can lead to injury, malfunction and damage.

It is the task of the person responsible for the equipment to inform the user about hazards and how to counteract them. The product is not to be operated until the user has been instructed on how to work with it.

5.3

Limits of Use

Environment

Suitable for use in an atmosphere appropriate for permanent human habitation: not suitable for use in aggressive or explosive environments.



DANGER

Local safety authorities and safety experts must be contacted before working in hazardous areas, or close to electrical installations or similar situations by the person in charge of the product.

5.4

Responsibilities

Manufacturer of the product

Leica Geosystems AG, CH-9435 Heerbrugg, hereinafter referred to as Leica Geosystems, is responsible for supplying the product, including the user manual and original accessories, in a safe condition.

Manufacturers of non Leica Geosystems accessories

The manufacturers of non Leica Geosystems accessories for the product are responsible for developing, implementing and communicating safety concepts for their products, and are also responsible for the effectiveness of those safety concepts in combination with the Leica Geosystems product.

Person in charge of the product

The person in charge of the product has the following duties:

- To understand the safety instructions on the product and the instructions in the user manual.
 - To be familiar with local regulations relating to safety and accident prevention.
 - To inform Leica Geosystems immediately if the product and the application becomes unsafe.
 - To ensure that the national laws, regulations and conditions for the operation of radio transmitters are respected.
-



WARNING

The person responsible for the product must ensure that it is used in accordance with the instructions. This person is also accountable for the training and the deployment of personnel who use the product and for the safety of the equipment in use.

5.5

Hazards of Use



WARNING

The absence of instruction, or the inadequate imparting of instruction, can lead to incorrect or adverse use, and can cause accidents with far-reaching human, material, financial and environmental consequences.

Precautions:

All users must follow the safety directions given by the manufacturer and the directions of the person responsible for the product.



CAUTION

Watch out for erroneous measurement results if the product has been dropped or has been misused, modified, stored for long periods or transported.

Precautions:

Periodically carry out test measurements and perform the field adjustments indicated in the user manual, particularly after the product has been subjected to abnormal use and before and after important measurements.



DANGER

Because of the risk of electrocution, it is dangerous to use poles and extensions in the vicinity of electrical installations such as power cables or electrical railways.

Precautions:

Keep at a safe distance from electrical installations. If it is essential to work in this environment, first contact the safety authorities responsible for the electrical installations and follow their instructions.

**WARNING**

During dynamic applications, for example stakeout procedures there is a danger of accidents occurring if the user does not pay attention to the environmental conditions around, for example obstacles, excavations or traffic.

Precautions:

The person responsible for the product must make all users fully aware of the existing dangers.

WARNING

Inadequate securing of the working site can lead to dangerous situations, for example in traffic, on building sites, and at industrial installations.

Precautions:

Always ensure that the working site is adequately secured. Adhere to the regulations governing safety and accident prevention and road traffic.

**WARNING**

If computers intended for use indoors are used in the field there is a danger of electric shock.

Precautions:

Adhere to the instructions given by the computer manufacturer regarding field use with Leica Geosystems products.

**CAUTION**

If the accessories used with the product are not properly secured and the product is subjected to mechanical shock, for example blows or falling, the product may be damaged or people can sustain injury.

Precautions:

When setting-up the product, make sure that the accessories are correctly adapted, fitted, secured, and locked in position.

Avoid subjecting the product to mechanical stress.

**WARNING**

If the product is used with accessories, for example masts, staffs, poles, you may increase the risk of being struck by lightning.

Precautions:

Do not use the product in a thunderstorm.

**DANGER**

If the product is used with accessories, for example on masts, staffs, poles, you may increase the risk of being struck by lightning. Danger from high voltages also exists near power lines. Lightning, voltage peaks, or the touching of power lines can cause damage, injury and death.

Precautions:

- Do not use the product in a thunderstorm as you can increase the risk of being struck by lightning.
 - Be sure to remain at a safe distance from electrical installations. Do not use the product directly under or close to power lines. If it is essential to work in such an environment contact the safety authorities responsible for electrical installations and follow their instructions.
 - If the product has to be permanently mounted in an exposed location, it is advisable to provide a lightning conductor system. A suggestion on how to design a lightning conductor for the product is given below. Always follow the regulations in force in your country regarding grounding antennas and masts. These installations must be carried out by an authorised specialist.
 - To prevent damages due to indirect lightning strikes (voltage spikes) cables, for example for antenna, power source or modem should be protected with appropriate protection elements, like a lightning arrester. These installations must be carried out by an authorised specialist.
 - If there is a risk of a thunderstorm, or if the equipment is to remain unused and unattended for a long period, protect your product additionally by unplugging all systems components and disconnecting all connecting cables and supply cables, for example, instrument - antenna.
-

Lightning conductors

Suggestion for design of a lightning conductor for a GNSS system:

1) On non-metallic structures

Protection by air terminals is recommended. An air terminal is a pointed solid or tubular rod of conducting material with proper mounting and connection to a conductor. The position of four air terminals can be uniformly distributed around the antenna at a distance equal to the height of the air terminal.

The air terminal diameter should be 12 mm for copper or 15 mm for aluminium. The height of the air terminals should be 25 cm to 50 cm. All air terminals should be connected to the down conductors. The diameter of the air terminal should be kept to a minimum to reduce GNSS signal shading.

2) On metallic structures

Protection is as described for non-metallic structures, but the air terminals can be connected directly to the conducting structure without the need for down conductors.

Air terminal arrangement, plan view

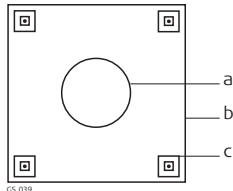

GS.039

- a) Antenna
- b) Support structure
- c) Air terminal

Grounding the instrument/antenna

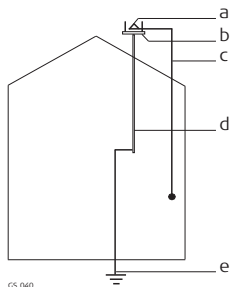

- a) Antenna
- b) Lightning conductor array
- c) Antenna/instrument connection
- d) Metallic mast
- e) Connection to earth

WARNING

Using a battery charger not recommended by Leica Geosystems can destroy the batteries. This can cause fire or explosions.

Precautions:

Only use chargers recommended by Leica Geosystems to charge the batteries.

CAUTION

During the transport, shipping or disposal of batteries it is possible for inappropriate mechanical influences to constitute a fire hazard.

Precautions:

Before shipping the product or disposing of it, discharge the batteries by running the product until they are flat.

When transporting or shipping batteries, the person in charge of the product must ensure that the applicable national and international rules and regulations are observed. Before transportation or shipping contact your local passenger or freight transport company.

**WARNING**

High mechanical stress, high ambient temperatures or immersion into fluids can cause leakage, fire or explosions of the batteries.

Precautions:

Protect the batteries from mechanical influences and high ambient temperatures. Do not drop or immerse batteries into fluids.

**WARNING**

If battery terminals come in contact with jewellery, keys, metallised paper or other metals, short circuited battery terminals can overheat and cause injury or fire, for example by storing or transporting in pockets.

Precautions:

Make sure that the battery terminals do not come into contact with metallic objects.

**WARNING**

Incorrect fastening of the external antenna to vehicles or transporters poses the risk of the equipment being broken by mechanical influence, vibration or airstream. This may result in accident and physical injury.

Precautions:

Attach the external antenna professionally. The external antenna must be secured additionally, for example by use of a safety cord. Ensure that the mounting device is correctly mounted and able to carry the weight of the external antenna (>1 kg) safely.

**WARNING**

If the product is improperly disposed of, the following can happen:

- If polymer parts are burnt, poisonous gases are produced which may impair health.
- If batteries are damaged or are heated strongly, they can explode and cause poisoning, burning, corrosion or environmental contamination.
- By disposing of the product irresponsibly you may enable unauthorised persons to use it in contravention of the regulations, exposing themselves and third parties to the risk of severe injury and rendering the environment liable to contamination.

Precautions:

The product must not be disposed with household waste. Dispose of the product appropriately in accordance with the national regulations in force in your country. Always prevent access to the product by unauthorised personnel.

Product-specific treatment and waste management information can be downloaded from the Leica Geosystems home page at

<http://www.leica-geosystems.com/treatment> or received from your Leica Geosystems dealer.



WARNING

Only Leica Geosystems authorised service workshops are entitled to repair these products.

5.6 Electromagnetic Compatibility EMC

Description

The term Electromagnetic Compatibility is taken to mean the capability of the product to function smoothly in an environment where electromagnetic radiation and electrostatic discharges are present, and without causing electromagnetic disturbances to other equipment.



WARNING

Electromagnetic radiation can cause disturbances in other equipment.

Although the product meets the strict regulations and standards which are in force in this respect, Leica Geosystems cannot completely exclude the possibility that other equipment may be disturbed.



CAUTION

There is a risk that disturbances may be caused in other equipment if the product is used with accessories from other manufacturers, for example field computers, personal computers, two-way radios, non-standard cables or external batteries.

Precautions:

Use only the equipment and accessories recommended by Leica Geosystems. When combined with the product, they meet the strict requirements stipulated by the guidelines and standards. When using computers and two-way radios, pay attention to the information about electromagnetic compatibility provided by the manufacturer.

 **CAUTION**

Disturbances caused by electromagnetic radiation can result in erroneous measurements.

Although the product meets the strict regulations and standards which are in force in this respect, Leica Geosystems cannot completely exclude the possibility that the product may be disturbed by intense electromagnetic radiation, for example, near radio transmitters, two-way radios or diesel generators.

Precautions:

Check the plausibility of results obtained under these conditions.

 **WARNING**

If the product is operated with connecting cables attached at only one of their two ends, for example external supply cables, interface cables, the permitted level of electromagnetic radiation may be exceeded and the correct functioning of other products may be impaired.

Precautions:

While the product is in use, connecting cables, for example product to external battery, product to computer, must be connected at both ends.

Radios or digital cellular phones

 **WARNING**

Use of product with radio or digital cellular phone devices:

Electromagnetic fields can cause disturbances in other equipment, in installations, in medical devices, for example pacemakers or hearing aids and in aircraft. It can also affect humans and animals.

Precautions:

Although the product meets the strict regulations and standards which are in force in this respect, Leica Geosystems cannot completely exclude the possibility that other equipment can be disturbed or that humans or animals can be affected.

- Do not operate the product with radio or digital cellular phone devices in the vicinity of filling stations or chemical installations, or in other areas where an explosion hazard exists.
 - Do not operate the product with radio or digital cellular phone devices near to medical equipment.
 - Do not operate the product with radio or digital cellular phone devices in aircraft.
-

5.7

FCC Statement, Applicable in U.S.



WARNING

The greyed paragraph below is only applicable for products without radio.

This equipment has been tested and found to comply with the limits for a Class B digital device, pursuant to part 15 of the FCC rules.

These limits are designed to provide reasonable protection against harmful interference in a residential installation.

This equipment generates, uses and can radiate radio frequency energy and, if not installed and used in accordance with the instructions, may cause harmful interference to radio communications. However, there is no guarantee that interference will not occur in a particular installation.



If this equipment does cause harmful interference to radio or television reception, which can be determined by turning the equipment off and on, the user is encouraged to try to correct the interference by one or more of the following measures:

- Reorient or relocate the receiving antenna.
 - Increase the separation between the equipment and the receiver.
 - Connect the equipment into an outlet on a circuit different from that to which the receiver is connected.
 - Consult the dealer or an experienced radio/TV technician for help.
-

⚠ WARNING

Changes or modifications not expressly approved by Leica Geosystems for compliance could void the user's authority to operate the equipment.

Labelling GS10

Type:	S.No.:
Art.No.:	
Equi.No.:	CE
Power:	
Leica Geosystems AG	FCC-ID: IC:
CH-9435 Heerbrugg	Contains transmitter module:
Manufactured:	FCC-ID:
Made in Switzerland	Bluetooth OPL:
 	
This device complies with part 15 of the FCC Rules. Operation is subject to the following two conditions: (1) This device may not cause harmful interference, and (2) this device must accept any interference received, including interference that may cause undesired operation.	

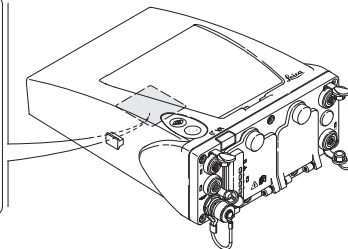

GS_096

Labelling internal battery GEB221, GEB222

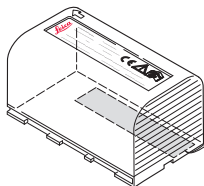

This device complies with part 15 of the FCC Rules. Operation is subject to the following two conditions: (1) This device may not cause harmful interference, and (2) this device must accept any interference received, including interference that may cause undesired operation.

UL US LISTED
ITE Accessory
E179078 . 70YL

GEB.002

Labelling GS15

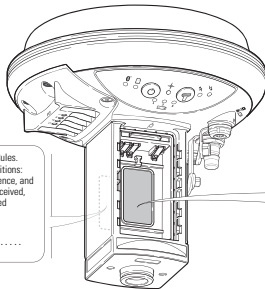

This device complies with part 15 of the FCC Rules. Operation is subject to the following two conditions: (1) This device may not cause harmful interference, and (2) this device must accept any interference received, including interference that may cause undesired operation.



.....

Type: S.No.:
 Equi.No.: Art.No.:
 Power:
 Leica Geosystems AG
 CH-9435 Heerbrugg IC:
 Manufactured: Contains transmitter module:
 Made in Switzerland FCC-ID:
 Bluetooth OPL:



GS.095

Labelling internal battery GEB211, GEB212

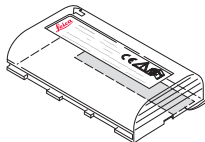

This device complies with part 15 of the FCC Rules. Operation is subject to the following two conditions: (1) This device may not cause harmful interference, and (2) this device must accept any interference received, including interference that may cause undesired operation.

UL US LISTED
ITE Accessory
E179078 . 70YL

GEB.001

6

Technical Data

6.1

GS10/GS15 Technical Data

6.1.1

Tracking Characteristics

Instrument technology

SmartTrack+

Satellite reception

Triple frequency

Instrument channels

GS10/GS15: Up to 16 channels continuous tracking on L1, L2 and L5 (GPS); up to 14 channels continuous tracking on L1 and L2 (GLONASS); up to 14 channels continuous tracking on E1, E5a, E5b and Alt-BOC (Galileo); four channels tracking SBAS (EGNOS, WAAS, MSAS, GAGAN).



Depending on the satellite systems and signals configured, a maximum number of 120 channels is allocated.

**Supported codes
and phases****GPS**

Type	L1	L2	L5
GS10/GS15	Carrier phase, C/A-code	Carrier phase, C code (L2C) and P2-code	Carrier phase, code

GLONASS

Type	L1	L2
GS10/GS15	Carrier phase, C/A-code	Carrier phase, P2-code

Galileo

Type	E1	E5a	E5b	Alt-BOC
GS10/GS15	Carrier phase, code	Carrier phase, code	Carrier phase, code	Carrier phase, code



Carrier phase and code measurements on L1, L2 and L5 (GPS) are fully independent with AS on or off.

Satellites tracked

Up to 16 simultaneously on L1, L2 and L5 (GPS) + up to 14 simultaneously on L1 and L2 (GLONASS) + up to 14 simultaneously on E1, E5a, E5b and Alt-BOC (Galileo) + up to four SBAS (EGNOS, WAAS, MSAS, GAGAN)

6.1.2

Accuracy



Accuracy is dependent upon various factors including the number of satellites tracked, constellation geometry, observation time, ephemeris accuracy, ionospheric disturbance, multipath and resolved ambiguities.

The following accuracies, given as **root mean square**, are based on measurements processed using LGO and on real-time measurements.

The use of multiple GNSS systems can increase accuracy by up to 30% relative to GPS only.

Differential code

The baseline precision of a differential code solution for static and kinematic surveys is 25 cm.

Differential phase
in post-processing

Static and rapid static

Static		Kinematic	
Horizontal	Vertical	Horizontal	Vertical
5 mm + 0.5 ppm	10 mm + 0.5 ppm	10 mm + 1 ppm	20 mm + 1 ppm

Static with long observations

Static		Kinematic	
Horizontal	Vertical	Horizontal	Vertical
3 mm + 0.1 ppm	3.5 mm + 0.4 ppm	10 mm + 1 ppm	20 mm + 1 ppm

Differential phase in real-time

Static		Kinematic	
Horizontal	Vertical	Horizontal	Vertical
5 mm + 0.5 ppm	10 mm + 0.5 ppm	10 mm + 1 ppm	20 mm + 1 ppm

6.1.3 Technical Data

Dimensions

The dimensions are given for the housing without the sockets.

Type	Length [m]	Width [m]	Thickness [m]
GS10	0.212	0.166	0.079

Type	Height [m]	Diameter [m]
GS15	0.198	0.196

Weight

Instrument weights without battery and radio:

Type	Weight [kg]/[lbs]
GS10	1.20/2.65
GS15	1.34/2.95

Recording

Data (Leica GNSS raw data and RINEX data) can be recorded on the SD card.

Type	Capacity [MB]	Data capacity
SD card	<ul style="list-style-type: none">1024	1024 MB is typically sufficient for about GPS only (12 satellites) <ul style="list-style-type: none">8000 h L1 + L2 + L5 data logging at 15 s rate32000 h L1 + L2 + L5 data logging at 60 s rate1440000 real-time points with codes GPS + GLONASS (12/8 satellites) <ul style="list-style-type: none">6800 h data logging at 15 s rate27200 h data logging at 60 s rate1440000 real-time points with codes GPS + GLONASS + Galileo (12/8/10 satellites) <ul style="list-style-type: none">3200 h data logging at 15 s rate12800 h data logging at 60 s rate1440000 real-time points with codes

Power

Power consumption:

GS10/GS15, radio excluded: 3.2 W typically, 270 mA

External supply voltage:

Nominal 12 V DC (---, GEV71 car battery cable to a 12 V car battery), voltage range 10.5 V-28 V DC

Internal battery

Type:

Li-Ion

Voltage:	7.4 V
Capacity:	GEB211: 2.2 Ah GEB212: 2.6 Ah GEB221: 4.4 Ah GEB222: 6.0 Ah

Battery external

Type:	NiMH
Voltage:	12 V
Capacity:	GEB171: 9.0 Ah

Operating times

The given operating times are valid for

- GS10: instrument plus antenna; two fully charged GEB222 batteries.
- GS15: instrument; two fully charged GEB212 batteries.
- room temperature. Operating times will be shorter when working in cold weather.

Equipment			Operating time
Type	Radio	Digital cellular phone	
Static (GS10)	-	-	27 h continuously
Static (GS15)	-	-	19 h continuously

Equipment			Operating time
Type	Radio	Digital cellular phone	
Rover (GS10)	SATELLINE M3-TR1, receive (GFU27)	-	20 h continuously
Rover (GS15)	SATELLINE M3-TR1, receive (SLR5)	-	10 h continuously
Rover (GS10)	-	Telit UC864-G (GFU28)	19 h continuously
Rover (GS15)	-	Telit UC864-G (SLG1)	7.5 h continuously

Electrical data

Type	GS15
Voltage	-
Current	-
Frequency	GPS L1 1575.42 MHz GPS L2 1227.60 MHz GPS L5 1176.45 MHz GLONASS L1 1602.5625 MHz-1611.5 MHz GLONASS L2 1246.4375 MHz-1254.3 MHz

Type	GS15
	Galileo E1 1575.42 MHz Galileo E5a 1176.45 MHz Galileo E5b 1207.14 MHz Galileo Alt-BOC 1191.795 MHz
Gain	Typically 27 dBi
Noise Figure	Typically < 2 dBi



Galileo Alt-BOC covers bandwidth of Galileo E5a and E5b.

Environmental specifications

Temperature

Type	Operating temperature [°C]	Storage temperature [°C]
All instruments	-40 to +65	-40 to +80
Leica SD cards	-40 to +80	-40 to +80
Battery internal	-20 to +55	-40 to +70

Protection against water, dust and sand

Type	Protection
All instruments	IP67 (IEC 60529) Dust tight Waterproof to 1 m temporary immersion

Humidity

Type	Protection
All instruments	Up to 100 % The effects of condensation are to be effectively counteracted by periodically drying out the instrument.

6.2 Antennas Technical Data

Description and use

The antenna is selected for use based upon the application. The table gives a description and the intended use of the individual antennas.

Type	Description	Use
AS05	L1 SmartTrack+ antenna with built-in ground plane.	With GS05/GS06 or GS10/GS25.
AS10	GPS, GLONASS, Galileo, Compass SmartTrack+ antenna with built-in ground plane.	With GS10/GS25.
AR10	GPS, GLONASS, Galileo, Compass antenna with large ground plane and built-in radome.	With GS10/GS25 where higher precision is required. For example static surveys of long baselines, tectonic plate monitoring and base stations.
AR25	Dorne & Margolin GPS, GLONASS, Galileo, Compass antenna element with 3D choke ring ground plane. Optional protective radome.	With GS10/GS25 where higher precision is required. For example static surveys of long baselines, tectonic plate monitoring and base stations.

Dimensions

Type	AS05/AS10	AR10	AR25
Height	6.2 cm	14.0 cm	20.0 cm
Diameter	17.0 cm	24.0 cm	38.0 cm

Connector

AS05/AS10/AR10: TNC female
AR25: N female

Mounting

All antennas: 5/8" Whitworth

Weight

AS05/AS10: 0.4 kg
AR10: 1.1 kg
AR25: 7.6 kg, radome 1.1 kg

Electrical data

Type	AS05	AS10	AR10	AR25
Voltage	4.5 V to 18 V DC	4.5 V to 18 V DC	3.3 V to 12 V DC	3.3 V to 12 V DC
Current	35 mA typical	35 mA typical	100 mA max	100 mA max
Frequency				

Type	AS05	AS10	AR10	AR25
GPS L1 1575.42 MHz	✓	✓	✓	✓
GPS L2 1227.60 MHz	-	✓	✓	✓
GPS L5 1176.45 MHz	-	✓	✓	✓
GLONASS L1 1602.5625- 1611.5 MHz	✓	✓	✓	✓
GLONASS L2 1246.4375- 1254.3 MHz	-	✓	✓	✓
Galileo E1 1575.42 MHz	-	✓	✓	✓
Galileo E5a 1176.45 MHz	-	✓	✓	✓
Galileo E5b 1207.14 MHz	-	✓	✓	✓

Type	AS05	AS10	AR10	AR25
Galileo Alt-BOC 1191.795 MHz	-	✓	✓	✓
Gain (typically)	27 dBi	29 dBi	29 dBi	40 dBi
Noise Figure (typically)	< 2 dBi	< 2 dBi	< 2 dBi	< 1.2 dBi max



Environmental specifications

Galileo Alt-BOC covers bandwidth of Galileo E5a and E5b.

Temperature

Type	Operating temperature [°C]	Storage temperature [°C]
AS05/AS10/AR10	-40 to +70	-55 to +85
AR25	-55 to +85	-55 to +90

Protection against water, dust and sand

Type	Protection
All antennas	IP67 (IEC 60529) Dust tight

Type	Protection
	Protected against water jets Waterproof to 1 m temporary immersion

Humidity

Type	Protection
All antennas	Up to 100 % The effects of condensation are to be effectively counteracted by periodically drying out the antenna.

Cable length

Separation distance from instrument ...	to antenna	Supplied cable lengths [m]	Optional cable lengths [m]
GS10	AS05/AS10/ AR10/AR25	1.2 2.8 10	30 50 70

6.3

Conformity to National Regulations

Conformity to national regulations

For products which do not fall under R&TTE directive:



Hereby, Leica Geosystems AG, declares that the product/s is/are in compliance with the essential requirements and other relevant provisions of the applicable European Directives. The declaration of conformity can be consulted at <http://www.leica-geosystems.com/ce>.

6.3.1

GS10

Conformity to national regulations

- FCC Part 15, 22 and 24 (applicable in US)
- Hereby, Leica Geosystems AG, declares that the product GS10 is in compliance with the essential requirements and other relevant provisions of Directive 1999/5/EC. The declaration of conformity can be consulted at <http://www.leica-geosystems.com/ce>.



- Class 1 equipment according European Directive 1999/5/EC (R&TTE) can be placed on the market and be put into service without restrictions in any EEA member state.
- The conformity for countries with other national regulations not covered by the FCC part 15, 22 and 24 or European directive 1999/5/EC has to be approved prior to use and operation.

Frequency band

Type	Frequency band [MHz]
GS10	1176.45 1191.795 1207.14 1227.60 1246.4375 - 1254.3 1575.42 1602.4375 - 1611.5
Bluetooth	2402 - 2480

Output power

Type	Output power [mW]
GNSS	Receive only
Bluetooth	5

Antenna

Type	Antenna	Gain [dBi]	Connector	Frequency band [MHz]
GNSS	External GNSS antenna element (receive only)	-	-	-

Type	Antenna	Gain [dBi]	Connector	Frequency band [MHz]
Bluetooth	Internal Microstrip antenna	1.5	-	-

6.3.2

GS15

Conformity to national regulations

- FCC Part 15, 22 and 24 (applicable in US)
- Hereby, Leica Geosystems AG, declares that the product GS15 is in compliance with the essential requirements and other relevant provisions of Directive 1999/5/EC. The declaration of conformity can be consulted at <http://www.leica-geosystems.com/ce>.



Class 1 equipment according European Directive 1999/5/EC (R&TTE) can be placed on the market and be put into service without restrictions in any EEA member state.

- The conformity for countries with other national regulations not covered by the FCC part 15, 22 and 24 or European directive 1999/5/EC has to be approved prior to use and operation.

Frequency band

Type	Frequency band [MHz]
GS15	1176.45 1191.795 1207.14 1227.60 1246.4375 - 1254.3 1575.42 1602.4375 - 1611.5

Type	Frequency band [MHz]
Bluetooth	2402 - 2480

Output power

Type	Output power [mW]
GNSS	Receive only
Bluetooth	5

Antenna

Type	Antenna	Gain [dBi]	Connector	Frequency band [MHz]
GNSS	Internal GNSS antenna element (receive only)	-	-	-
Bluetooth	Internal Microstrip antenna	1.5	-	-

6.3.3

GFU24, Siemens MC75

Conformity to national regulations

- FCC Part 15, 22 and 24 (applicable in US)
- Hereby, Leica Geosystems AG, declares that the GFU24 is in compliance with the essential requirements and other relevant provisions of Directive 1999/5/EC. The declaration of conformity may be consulted at <http://www.leica-geosystems.com/ce>.



Class 1 equipment according European Directive 1999/5/EC (R&TTE) can be placed on the market and be put into service without restrictions in any EEA Member state.

- The conformity for countries with other national regulations not covered by the FCC part 15, 22 and 24 or European directive 1999/5/EC has to be approved prior to use and operation.
-

Frequency band

Quad-Band EGSM850 MHz/ EGSM900 MHz/ GSM1800 MHz/ GSM1900 MHz

Output power

EGSM850/900:	2 W
GSM1800/1900:	1 W

Antenna

Type	GAT3	GAT5	GAT18
Frequency band [MHz]	890 - 960 / 1710 - 1880 / 1920 - 2170	824 - 894 / 1850 - 1990	824 - 894 / 890 - 960 / 1710 - 1880 / 1850 - 1990 / 1920 - 2170
Type	Detachable $\lambda/2$ antenna	Detachable $\lambda/2$ antenna	Detachable $\lambda/2$ antenna
Connector	TNC	TNC	TNC

Specific Absorption Rate (SAR)

The product meets the limits for the maximum permissible exposure of the guidelines and standards which are in force in this respect. The product must be used with the recommended antenna. A separation distance of at least 20 centimetres should be kept between the antenna and the body of the user or nearby person within the intended application.

6.3.4 GFU19 (US), GFU25 (CAN) CDMA MultiTech MTMMC-C

Conformity to national regulations

- FCC Part 15, 22 and 24 (applicable in US)
- The conformity for countries with other national regulations not covered by the FCC part 15, 22 and 24 has to be approved prior to use and operation.

Frequency band

Dual-Band CDMA850 MHz/CDMA1900 MHz

Output power

CDMA850: 2 W
CDMA1900: 0.4 W

Antenna

Type	GAT5	GAT18
Frequency band [MHz]	824 - 894 / 1850 -1990	824 - 894 / 890 - 960 / 1710 - 1880 / 1850 - 1990 / 1920 - 2170
Type	Detachable $\lambda/2$ antenna	Detachable $\lambda/2$ antenna
Connector	TNC	TNC

Specific Absorption Rate (SAR)

The product meets the limits for the maximum permissible exposure of the guidelines and standards which are force in this respect. The product must be used with the recommended antenna. A separation distance of at least 20 centimetres should be kept between the antenna and the body of the user or nearby person within the intended application.

6.3.5

GFU28, Telit UC864-G

Conformity to national regulations

- FCC Part 15, 22 and 24 (applicable in US)
- Hereby, Leica Geosystems AG, declares that the GFU28 is in compliance with the essential requirements and other relevant provisions of Directive 1999/5/EC. The declaration of conformity may be consulted at <http://www.leica-geosystems.com/ce>.



Class 1 equipment according European Directive 1999/5/EC (R&TTE) can be placed on the market and be put into service without restrictions in any EEA Member state.

- The conformity for countries with other national regulations not covered by the FCC part 15, 22 and 24 or European directive 1999/5/EC has to be approved prior to use and operation.
-

Frequency band

UMTS/HSDPA (WCDMA/FDD) 850 MHz/ 1900 MHz/ 2100 MHz
Quad-Band EGSM 850 MHz/ 900 MHz/ 1800 MHz/ 1900 MHz
GPRS multi-slot class 12
EDGE multi-slot class 12

Output power

EGSM850/900:	2 W
GSM1800/1900:	1 W
UMTS2100:	0.25 W
EDGE850/900:	0.5 W

EDGE1800/1900: 0.4 W

Antenna

Type	Internal	GAT3	GAT5	GAT18
Frequency band [MHz]	824 - 894 / 890 - 960 / 1710 - 1880 / 1850 - 1990 / 1920 - 2170	890 - 960 / 1710 - 1880 / 1920 - 2170	824 - 894 / 1850 - 1990	824 - 894 / 890 - 960 / 1710 - 1880 / 1850 - 1990 / 1920 - 2170
Type	Internal	Detachable $\lambda/2$ antenna	Detachable $\lambda/2$ antenna	Detachable $\lambda/2$ antenna
Connector	-	TNC	TNC	TNC

Specific Absorption Rate (SAR)

The product meets the limits for the maximum permissible exposure of the guidelines and standards which are force in this respect. The product must be used with the recommended antenna. A separation distance of at least 20 centimetres should be kept between the antenna and the body of the user or nearby person within the intended application.

6.3.6

SLR1, SLR2, SATEL SATELLINE-3AS

Conformity to national regulations

- FCC Part 15 (applicable in US)
- Hereby, Leica Geosystems AG, declares that the product SLR1, SLR2 is in compliance with the essential requirements and other relevant provisions of Directive 1999/5/EC. The declaration of conformity can be consulted at <http://www.leica-geosystems.com/ce>.



Class 2 equipment according European Directive 1999/5/EC (R&TTE) for which following EEA Member States apply restrictions on the placing on the market or on the putting into service or require authorisation for use:

- France
 - Italy
 - Norway (if used in the geographical area within a radius of 20km from the centre of Ny-Ålesund)
- The conformity for countries with other national regulations not covered by the FCC part 15 or European directive 1999/5/EC has to be approved prior to use and operation.

Frequency band

403 MHz - 470 MHz

Output power

SLR1: 0.5 W-1.0 W
 SLR2: Receive only

Antenna

Type	Internal	GAT1	GAT2
Frequency band [MHz]	400 - 470	400 - 435	435 - 470
Type	Internal	Detachable $\lambda/2$ antenna	Detachable $\lambda/2$ antenna
Connector	-	TNC	TNC

Specific Absorption Rate (SAR)

The product meets the limits for the maximum permissible exposure of the guidelines and standards which are force in this respect. The product must be used with the recommended antenna. A separation distance of at least 20 centimetres should be kept between the antenna and the body of the user or nearby person within the intended application.

6.3.7

SLR5, SATEL SATELLINE M3-TR1

Conformity to national regulations

- FCC Part 15 (applicable in US)
- Hereby, Leica Geosystems AG, declares that the product SLR5 is in compliance with the essential requirements and other relevant provisions of Directive 1999/5/EC. The declaration of conformity can be consulted at <http://www.leica-geosystems.com/ce>.



Class 2 equipment according European Directive 1999/5/EC (R&TTE) for which following EEA Member States apply restrictions on the placing on the market or on the putting into service or require authorisation for use:

- France
 - Italy
 - Norway (if used in the geographical area within a radius of 20km from the centre of Ny-Ålesund)
- The conformity for countries with other national regulations not covered by the FCC part 15 or European directive 1999/5/EC has to be approved prior to use and operation.

Frequency band

403 MHz - 470 MHz

Output power

SLR5: 0.5 W-1.0 W

Antenna

Type	Internal	GAT1	GAT2
Frequency band [MHz]	400 - 470	400 - 435	435 - 470
Type	Internal	Detachable $\lambda/2$ antenna	Detachable $\lambda/2$ antenna
Connector	-	TNC	TNC

Specific Absorption Rate (SAR)

The product meets the limits for the maximum permissible exposure of the guidelines and standards which are force in this respect. The product must be used with the recommended antenna. A separation distance of at least 20 centimetres should be kept between the antenna and the body of the user or nearby person within the intended application.

6.3.8

SLR3-1, SLR3-2, Pacific Crest ADL

Conformity to national regulations

- FCC Part 15 (applicable in US)
- Hereby, Leica Geosystems AG, declares that the product SLR3-1, SLR3-2 is in compliance with the essential requirements and other relevant provisions of Directive 1999/5/EC. The declaration of conformity can be consulted at <http://www.leica-geosystems.com/ce>.



Class 2 equipment according European Directive 1999/5/EC (R&TTE) for which following EEA Member States apply restrictions on the placing on the market or on the putting into service or require authorisation for use:

- France
 - Italy
 - Norway (if used in the geographical area within a radius of 20km from the centre of Ny-Ålesund)
- The conformity for countries with other national regulations not covered by the FCC part 15 or European directive 1999/5/EC has to be approved prior to use and operation.

Frequency band

SLR3-1:	390 MHz - 430 MHz
SLR3-2:	430 MHz - 470 MHz

Output power

SLR3-1: 0.5 W-1 W
SLR3-2: 0.5 W-1 W

Antenna

Type	Internal	GAT1	GAT2
Frequency band [MHz]	400 - 470	400 - 435	435 - 470
Type	Internal	Detachable $\lambda/2$ antenna	Detachable $\lambda/2$ antenna
Connector	-	TNC	TNC

Specific Absorption Rate (SAR)

The product meets the limits for the maximum permissible exposure of the guidelines and standards which are force in this respect. The product must be used with the recommended antenna. A separation distance of at least 20 centimetres should be kept between the antenna and the body of the user or nearby person within the intended application.

6.3.9

SLG1, Telit UC864-G

Conformity to national regulations

- FCC Part 15, 22 and 24 (applicable in US)
- Hereby, Leica Geosystems AG, declares that the SLG1 is in compliance with the essential requirements and other relevant provisions of Directive 1999/5/EC. The declaration of conformity may be consulted at <http://www.leica-geosystems.com/ce>.



- Class 1 equipment according European Directive 1999/5/EC (R&TTE) can be placed on the market and be put into service without restrictions in any EEA Member state.
- The conformity for countries with other national regulations not covered by the FCC part 15, 22 and 24 or European directive 1999/5/EC has to be approved prior to use and operation.
-

Frequency band

UMTS/HSDPA (WCDMA/FDD) 850 MHz/ 1900 MHz/ 2100 MHz
Quad-Band EGSM 850 MHz/ 900 MHz/ 1800 MHz/ 1900 MHz
GPRS multi-slot class 12
EDGE multi-slot class 12

Output power

EGSM850/900:	2 W
GSM1800/1900:	1 W
UMTS2100:	0.25 W
EDGE850/900:	0.5 W

EDGE1800/1900: 0.4 W

Antenna

Type	Internal	GAT3	GAT5	GAT18
Frequency band [MHz]	824 - 894 / 890 - 960 / 1710 - 1880 / 1850 - 1990 / 1920 - 2170	890 - 960 / 1710 - 1880 / 1920 - 2170	824 - 894 / 1850 - 1990	824 - 894 / 890 - 960 / 1710 - 1880 / 1850 - 1990 / 1920 - 2170
Type	Internal	Detachable $\lambda/2$ antenna	Detachable $\lambda/2$ antenna	Detachable $\lambda/2$ antenna
Connector	-	TNC	TNC	TNC

Specific Absorption Rate (SAR)

The product meets the limits for the maximum permissible exposure of the guidelines and standards which are force in this respect. The product must be used with the recommended antenna. A separation distance of at least 20 centimetres should be kept between the antenna and the body of the user or nearby person within the intended application.

6.3.10

SLG2, CINTERION MC75i

Conformity to national regulations

- FCC Part 15, 22 and 24 (applicable in US)
- Hereby, Leica Geosystems AG, declares that the SLG2 is in compliance with the essential requirements and other relevant provisions of Directive 1999/5/EC. The declaration of conformity may be consulted at <http://www.leica-geosystems.com/ce>.



Class 1 equipment according European Directive 1999/5/EC (R&TTE) can be placed on the market and be put into service without restrictions in any EEA Member state.

- The conformity for countries with other national regulations not covered by the FCC part 15, 22 and 24 or European directive 1999/5/EC has to be approved prior to use and operation.
-

Frequency band

Quad-Band EGSM850 MHz/ EGSM900 MHz/ GSM1800 MHz/ GSM1900 MHz

Output power

EGSM850/900:	2 W
GSM1800/1900:	1 W

Antenna

Type	Internal	GAT3	GAT5	GAT18
Frequency band [MHz]	824 - 894 / 890 - 960 / 1710 - 1880 / 1850 - 1990 / 1920 - 2170	890 - 960 / 1710 - 1880 / 1920 - 2170	824 - 894 / 1850 - 1990	824 - 894 / 890 - 960 / 1710 - 1880 / 1850 - 1990 / 1920 - 2170
Type	Internal	Detachable $\lambda/2$ antenna	Detachable $\lambda/2$ antenna	Detachable $\lambda/2$ antenna
Connector	-	TNC	TNC	TNC

Specific Absorption Rate (SAR)

The product meets the limits for the maximum permissible exposure of the guidelines and standards which are in force in this respect. The product must be used with the recommended antenna. A separation distance of at least 20 centimetres should be kept between the antenna and the body of the user or nearby person within the intended application.

6.3.11 SLC1 (US), SLC2 (US) CDMA Telit CC864-DUAL

Conformity to national regulations

- FCC Part 15, 22 and 24 (applicable in US)
- The conformity for countries with other national regulations not covered by the FCC part 15, 22 and 24 has to be approved prior to use and operation.

Frequency band

Dual-Band CDMA800 MHz/CDMA1900 MHz

Output power

CDMA800: 0.27 W
CDMA1900: 0.4 W

Antenna

Type	Internal	GAT5	GAT18
Frequency band [MHz]	824 - 894 / 890 - 960 / 1710 - 1880 / 1850 - 1990 / 1920 - 2170	824 - 894 / 1850 - 1990	824 - 894 / 890 - 960 / 1710 - 1880 / 1850 - 1990 / 1920 - 2170
Type	Internal	Detachable $\lambda/2$ antenna	Detachable $\lambda/2$ antenna
Connector	-	TNC	TNC

Specific Absorption Rate (SAR)

The product meets the limits for the maximum permissible exposure of the guidelines and standards which are force in this respect. The product must be used with the recommended antenna. A separation distance of at least 20 centimetres should be kept between the antenna and the body of the user or nearby person within the intended application.

7 International Limited Warranty, Software Licence Agreement

International Limited Warranty

This product is subject to the terms and conditions set out in the International Limited Warranty which you can download from the Leica Geosystems home page at <http://www.leica-geosystems.com/internationalwarranty> or collect from your Leica Geosystems distributor. The foregoing warranty is exclusive and is in lieu of all other warranties, terms or conditions, expressed or implied, either in fact or by operation of law, statutory or otherwise, including warranties, terms or conditions of merchantability, fitness for a particular purpose, satisfactory quality and non-infringement, all which are expressly disclaimed.

Software Licence Agreement

This product contains software that is preinstalled on the product, or that is supplied to you on a data carrier medium, or that can be downloaded by you online according to prior authorisation from Leica Geosystems. Such software is protected by copyright and other laws and its use is defined and regulated by the Leica Geosystems Software Licence Agreement, which covers aspects such as, but not limited to, Scope of the Licence, Warranty, Intellectual Property Rights, Limitation of Liability, Exclusion of other Assurances, Governing Law and Place of Jurisdiction. Please make sure, that at any time you fully comply with the terms and conditions of the Leica Geosystems Software Licence Agreement.

Such agreement is provided together with all products and can also be referred to and downloaded at the Leica Geosystems home page at <http://www.leica-geosystems.com/swlicense> or collected from your Leica Geosystems distributor.

You must not install or use the software unless you have read and accepted the terms and conditions of the Leica Geosystems Software Licence Agreement. Installation or use of the software or any part thereof, is deemed to be an acceptance of all the terms and conditions of such Licence Agreement. If you do not agree to all or some of the terms of such Licence Agreement, you must not download, install or use the software and you must return the unused software together with its accompanying documentation and the purchase receipt to the distributor from whom you purchased the product within ten (10) days of purchase to obtain a full refund of the purchase price.

Appendix A Pin Assignments and Sockets

A.1 GS10

Description

Some applications require knowledge of the pin assignments for the GS10 ports. In this chapter, the pin assignments and sockets for the ports of the GS10 are explained.

Ports at the instrument front panel

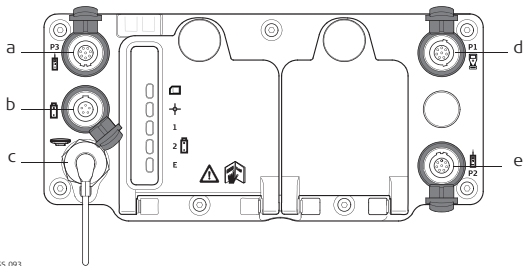

- a) Port P3: Power out, data in/out or remote interface in/out. 8 pin LEMO
- b) Port PWR: Power in. 5 pin LEMO
- c) Port ANT: GNSS antenna in
- d) Port P1: CS field controller in/out or remote interface in/out. 8 pin LEMO
- e) Port P2: Power out, data in/out or remote interface in/out. 8 pin LEMO

Pin assignments for port P1



PIN_001

Pin	Signal Name	Function	Direction
1	USB_D+	USB data line	In or out
2	USB_D-	USB data line	In or out
3	GND	Signal ground	-
4	RxD	RS232, receive data	In
5	TxD	RS232, transmit data	Out
6	ID	Identification pin	In or out
7	PWR	Power input, 10.5 V-28 V	In
8	TRM_ON/USB_ID	RS232, general-purpose signal	In or out

Pin assignments for port P2, and port P3

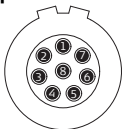

PIN_003

Pin	Signal Name	Function	Direction
1	RTS	RS232, ready to send	Out
2	CTS	RS232, clear to send	In
3	GND	Signal ground	-
4	RxD	RS232, receive data	In
5	TxD	RS232, transmit data	Out
6	ID	Identification pin	In
7	GPIO	RS232, configurable function	In or out
8	+12 V	12 V power supply out	Out

Pin assignments for port PWR

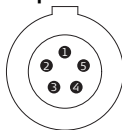

PIN_004

Pin	Signal Name	Function	Direction
1	PWR1	Power input, 11 V-28 V	In
2	ID1	Identification pin	In
3	GND	Signal ground	-
4	PWR2	Power input, 11 V-28 V	In
5	ID2	Identification pin	In

Sockets

Port P1	LEMO-1, 8 pin, LEMO EGI.1B.308.CLN
Port P2 and port P3:	LEMO-1, 8 pin, LEMO HMA.1B.308.CLNP
Port PWR:	LEMO-1, 5 pin, LEMO HMG.1B.305.CLNP

A.2**GS15****Description**

Some applications require knowledge of the pin assignments for the GS15 ports. In this chapter, the pin assignments and sockets for the ports of the GS15 are explained.

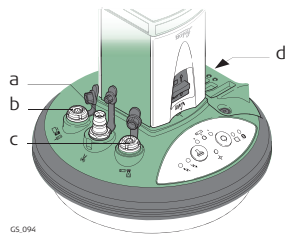
Ports at the instrument underside

- a) QN-connector
- b) Port 2
- c) Port 1 (USB and serial)
- d) Port 3

Pin assignments for port P1

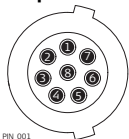

PIN_001

Pin	Signal Name	Function	Direction
1	USB_D+	USB data line	In or out
2	USB_D-	USB data line	In or out
3	GND	Signal ground	-
4	RxD	RS232, receive data	In
5	TxD	RS232, transmit data	Out
6	ID	Identification pin	In or out
7	PWR	Power input, 10.5 V-28 V	In
8	TRM_ON/USB_ID	RS232, general-purpose signal	In or out

Pin assignments for port P2

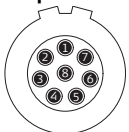

PIN_003

Pin	Signal Name	Function	Direction
1	RTS	RS232, ready to send	Out
2	CTS	RS232, clear to send	In
3	GND	Signal ground	-
4	RxD	RS232, receive data	In
5	TxD	RS232, transmit data	Out
6	ID	Identification pin	In

Pin	Signal Name	Function	Direction
7	GPIO	RS232, configurable function	In or out
8	+12 V	12 V power supply out	Out

Pin assignments for port P3

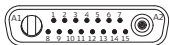

PIN_005

Pin	Signal Name	Function	Direction
1	PWR	4 V power supply in	In
2	Tx	Transmit data	In
3	Rx	Receive data	Out
4	GPO/DCD	General-purpose out, carrier detect out	Out
5	RTS	Request to send	In
6	CTS	Clear to send	Out
7	GPI/CFG	General-purpose in, config mode in	In
8	PWR	6 V power supply in	In
9	GPIO	General-purpose signal	In or out
10	GND	Signal and chassis ground	-
11	USB+	USB data line (+)	In or out
12	USB-	USB data line (-)	In or out

Pin	Signal Name	Function	Direction
13	GND	Signal and chassis ground	-
14	ID	Identification pin	In or out
15	GPIO	General-purpose signal	In or out
A1	NC	Not used	-
A2	RF1	Antenna port, radio to antenna	-

Sockets

Port 1: LEMO-1, 8 pin, LEMO EGI.1B.308.CLN
 Port 2: LEMO-1, 8 pin, LEMO HMA.1B.308.CLNP
 Port 3: 15 pin RS232:RS232, 15 pin, DE15

Index

A

AC, power supply unit	15
ActiveSync	27
Antenna	
GS10	112
GS15	115
Antennas	106
Type	106

B

Batteries	
Charging, first-time use	39
Operation, Discharging	39
Battery	
Change in GS10	40
Change in GS15	42
External, instrument	102
For internal power supply	15
Internal, instrument	101
Bluetooth	
LED on GS10	64
LED on GS15	64

Buttons

Combined pressing	24
Function	21
ON/OFF	21

C

Capacity, memory	
Instrument	101
CINTERION MC75i	
SLG2, technical data	130
Clip-on-housing	
Attach	49
Detach	49
Connector, antennas	107

D

Data recording	
Leica GNSS raw data	101
RINEX	101
Description of the system	11
Device	
Status	52, 60

Dimensions		GS10	112
Antennas	107	GS15	114
Instruments	100	SLC1, Telit CC864-DUAL	132
Documentation	4	SLC2, Telit CC864-DUAL	132
Drive		SLG1, Telit UC864-G	128
PC card, on office computer	17	SLG2, CINTERION MC75i	130
E		SLR1, SATEL SATELLINE-3AS	122
Electrical data		SLR2, SATEL SATELLINE-3AS	122
Antenna	107	SLR3-1, Pacific Crest	126
GS15	103	SLR3-2, Pacific Crest	126
Environmental specifications		SLR5, SATEL SATELLINE M3-TR1	124
Antenna	109	G	
Instrument	104	GAT 1, antenna	123, 125, 127
External power supply	15	GAT 2, antenna	123, 125, 127
F		GAT 3, antenna	117, 121, 129, 131
FCC Statement	91	GAT 5, antenna	117, 118, 121, 129, 131, 132
Flashing LED on clip-on-housing	55	GAT18, antenna	117, 118, 121, 129, 131, 132
Flashing LED on slot-in device	62, 62	GFU19	118
Frequency band		GFU24	116
GFU19, MultiTech MTMMC-C	118	GFU25	118
GFU24, Siemens MC75	116	GFU28	120
GFU25, MultiTech MTMMC-C	118	GS	
GFU28, Telit UC864-G	120	Firmware for GS10 and GS15	13

Language software for GS10 and GS15	13	Slot-in-device	58
GS10		Instrument components	18
Configure base mode	37	Instruments	11
Configure rover mode	37	Intended Use	74
Insert SD card	44	Internal power supply	15
Remove SD card	44	International Limited Warranty	134
Status	64		
Technical data	95	K	
GS15		Keyboard	
Configure base mode	37	GS10	20
Configure rover mode	37	GS15	20
Insert SD card	46		
Remove SD card	46	L	
Status	64	Labelling	
Technical data	95	GEB211	94
		GEB212	94
		GEB221	93
		GEB222	93
		GS10	92
I		GS15	93
Indicators, LED		LED	
GS10	64	Clip-on-housing	52
GS15	64	Clip-on-housing, description	53
Indicators, LED for clip-on-housing	52	Slot-in-device	60
Indicators, LED for slot-in-device	60	Slot-in-device, description	61
Insert			
SIM card	51, 59		

LED, Description	
GS10	65
GS15	65
LEICA	
Geo Office	11
Light Emitting Diode	
GS10	64
GS15	64
Light Emitting Diode, clip-on-housing	52
Light Emitting Diode, slot-in-device	60
Li-Ion battery	101
Storage	71

M

Memory device	
Available	17
Microsoft ActiveSync	27
Mount, antennas	107
MultiTech MTMMC-C	
GFU19/GFU25, technical data	118

N

NiCd battery	102
--------------------	-----

O

Operating times	
GS10	102
GS15	102
Output power	
GFU19, MultiTech MTMMC-C	118
GFU24, Siemens MC75	116
GFU25, MultiTech MTMMC-C	118
GFU28, Telit UC864-G	120
GS10	112, 115
GS15	112, 115
SLC1, Telit CC864-DUAL	132
SLC2, Telit CC864-DUAL	132
SLG1, Telit UC864-G	128
SLG2, CINTERION MC75i	130
SLR1, SATEL SATELLINE-3AS	122
SLR2, SATEL SATELLINE-3AS	122
SLR3-1, Pacific Crest	127
SLR3-2, Pacific Crest	127
SLR5, SATEL SATELLINE M3-TR1	124

P

Pacific Crest	
SLR3-1, technical data	126

SLR3-2, technical data	126	LED on GS10	64
PC card drive on office computer	17	LED on GS15	64
Pin Assgiment	136	RTK Rover	
Position		Configure on GS10	37
LED on GS10	64	Configure on GS15	37
LED on GS15	64	LED on GS10	64
Power LED		LED on GS15	64
GS10	64	S	
GS15	64	Safety Directions	73
Power supply	15	SATELLINE	
Power, instruments	101	SLR1, technical data	122
R		SLR2, technical data	122
Raw data logging		SLR5, technical data	124
Leica GNSS	17, 101	SD card	
RINEX	17, 101	Insert	44, 46
Recording	101	Memory device	17
Remove		Remove	44, 46
SIM card	51, 59	Siemens MC75	
Slot-in-device	58	GFU24, technical data	116
Responsibilities	77	SIM card	
RTK Base		Insert	51, 59
Configure on GS10	37	Remove	51, 59
Configure on GS15	37	SLC1	132

SLC2	132	LED on GS15	64
SLG1	128		
SLG2	130	T	
Slot-in-device		Telit CC864-DUAL	
Insert	58	SLC1, technical data	132
Remove	58	SLC2, technical data	132
SLR1	122	Telit UC864-G	
SLR2	122	GFU28, technical data	120
SLR3-1	126	SLG1, technical data	128
SLR3-2	126	Temperature	
SLR5	124	Antenna	
Socket	136	Operating	109
Software		Storage	109
Upload	14	Battery internal	
Software Licence Agreement	134	Operating	104
Specifications, environmental		Storage	104
Antennas	109	Instrument	
Instrument	104	Operating	104
Status		Storage	104
GS10	64	SD card	
GS15	64	Operating	104
Status, device	52, 60	Storage	104
Storage		Temperature range	
LED on GS10	64	Product, drying	72

Temperature, charging internal battery 39

Time, operating 102

U

Uninterruptible Power Supply 16

Upload software 14

UPS 16

User Interface 20

User Manual

 Validity of 4

W

Web server 11

Weight

 Antennas 107

 Instrument 100

Windows Mobile Device Center 27

Total Quality Management: Our commitment to total customer satisfaction.



Leica Geosystems AG, Heerbrugg, Switzerland, has been certified as being equipped with a quality system which meets the International Standards of Quality Management and Quality Systems (ISO standard 9001) and Environmental Management Systems (ISO standard 14001).

Ask your local Leica Geosystems dealer for more information about our TQM program.

Leica Geosystems AG

Heinrich-Wild-Strasse
CH-9435 Heerbrugg
Switzerland
Phone +41 71 727 31 31

www.leica-geosystems.com

- when it has to be **right**

Leica
Geosystems

772916-4.1.0en

Original text
Printed in Switzerland
© 2012 Leica Geosystems AG, Heerbrugg, Switzerland