



INTELLIGENT SOLUTIONS FOR SITE CONSTRUCTION



TABLE OF CONTENTS

INTELLIGENT JOBSITE



Jobsite Connectivity 3

OFF-MACHINE SOLUTIONS



Construction Layout 7



Volume Calculations 9















Grade Checking 11



Off-Machine Tools 13

ON-MACHINE SOLUTIONS

-  3D Machine Control Panel 19
-  2D Machine Control Panel 23
-  Excavator System 25
-  Dozer System 35
-  Grader System 47
-  Wheel Loader System 57
-  Drilling System 63
-  Piling System 65
-  Concrete Paving System 69
-  Kerb & Gutter System 73
-  Asphalt Paving System 77
-  Milling System 81
-  Roller System 85

SERVICES



HxGN SMARTNET
87



CUSTOMER CARE PACKAGES
89

SHARP GRADE LEVELLER



PRECISION LASER LEVELLER
91

INTELLIGENT JOBSITE

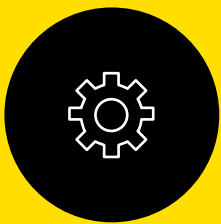

Productivity

Reduce waste and rework with a digitally integrated workflow that takes your construction activity to a whole new level.



Sharing

Increase transparency, avoid costly miscommunication and respond quickly and efficiently to design updates by sharing changes and corrections to the reference model data in real time across the project.

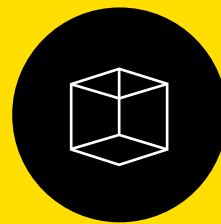

Visualizing

Use 2D and 3D data to validate activities, communicate designs, and engage stakeholders with interactive maps for productivity-boosting collaboration.

Complete your projects on time, on budget and on specification by monitoring efficiencies, validating volumetric measurements and keeping your team fully informed at all times. With intelligent construction, you get complete visibility into every aspect of your jobsite when and where you need it for the ultimate control.

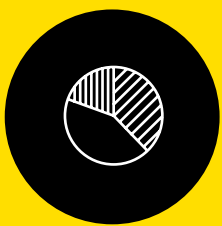

Monitoring

Avoid costly errors, increase efficiency and maximize profitability by knowing the true utilization of machine control operations, remotely assigning work and providing positioning and reference data to operators and grade checkers.



Reporting

Avoid unnecessary surprises and keep your projects on schedule with easy access to timely and insightful reporting on productivity, work progress and validation of completed tasks.



Documenting

Protect your business and your bottom line by being able to document all your completed work, such as amounts of earth moved, construction activities performed, and whether those activities have been performed to specification.

Jobsite Connectivity

Gain the ultimate transparency into your construction activity and monitor progress in real time from anywhere on any device.



Leica ConX

Easily visualize and share data through a powerful cloud solution and web interface.

This cloud-based collaboration tool allows you to efficiently manage all your connected construction projects, including third party platforms, and share job-related data with all stakeholders. With Leica ConX, you will be able to visualize and validate localized reference models, survey data and constructed data.



Monitor your productivity in real-time.



- Visualize, manage, and share 3D data in the cloud
- Connect to field equipment to share reference models and measurements
- Connect to machines for remote support and sharing 3D project data
- Share as-built data from machines to Leica ConX and between machines
- Share measured data from surveyors to Leica ConX
- Monitor project production from Leica ConX Cloud
- Measure and track volumetric progress and material movement
- Measure and track utilization on ConX Cloud

OFF-MACHINE SOLUTIONS



Construction Layout

Quickly layout points and lines for various site scenarios. Whether you need the accuracy of a total station or the freedom of a rover, you're covered.



Volume Calculations

Access accurate and reliable data in minutes right from the field with best-in-class tools and software that provide the quickest and easiest volume routines.



Grade Checking

On foot or wheels, get fast, accurate, easy to understand cut/fill data to ensure you are progressing rapidly toward finish grade, slope, and compaction.



Maximize your investment with flexible hardware and software solutions that allow you to carry out critical positioning tasks with confidence. These on-the-ground solutions not only increase your efficiency, but your peace of mind as well.



Machine Guidance

Ensure your operators have the right information to get to grade quickly and easily the first time by seamlessly integrating on-machine solutions.

Construction Layout

Work faster and more accurately with flexible options for laying out any element of your design.



Stake Out

Stake out road course, crossroads, layout pads, roads and intersections, utilities, and detention ponds.

As-built

Capture the as-built state of your finished product.

The iCON site software is the backbone of off-machine heavy construction applications. In combination with Leica iCON robots and Leica iCON gps, layout related activities are easier than ever with this intuitive software.

A GNSS setup allows you to go where others cannot – offering ultimate flexibility when obstacles deny you line of site. Work with multiple antennas on site from a single base station or connect to our HxGN SmartNet network for ultimate efficiency.

Robotic total stations allow greater precision and can work indoors or even under ground.



Volume Calculations

Capture and calculate volumes faster and easier than ever before.



Volume Matters

Documenting and validating quantities of earth being moved or used will protect your bottom line.

Rapidly capture any feature with Leica GPS or Robotic Total Stations and instantly see its volume, area, balanced elevation, and more with Leica iCON site's innovative volume calculation routine.

- Calculate the volume of a stockpile or pit and easily make comparisons between surfaces or to the elevation.
- Add breaklines on the fly to any surface for more precise modeling.
- Apply shrink or swell factors to accurately calculate needed volumes.
- Read out balanced site elevation.
- Balance out Cut & Fill for optimized material and machine usage.
- Monitor the ongoing progress of your earthworks.



Result screen/view for volume calculation

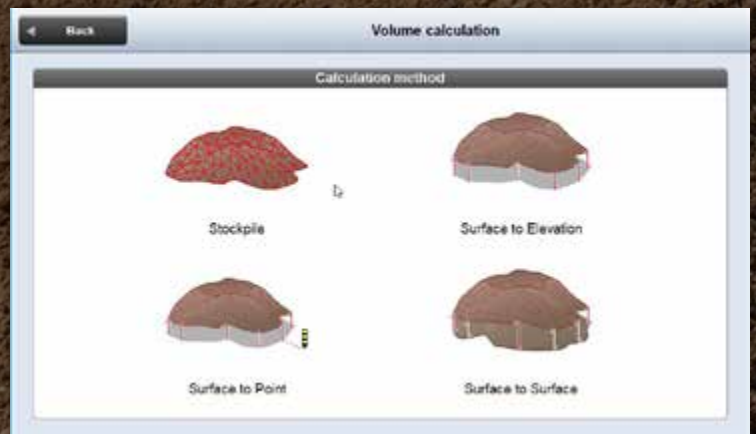

Selection of different volume calculation methods



Tools to create/edit surfaces and calculate volumes

Grade Checking

Achieve reliable rough and fine grade checking for a multitude of applications.



Whether you are taking cut and fill measurements or checking rough and fine grade, Leica iCON site offers robotic total station and GNSS options.

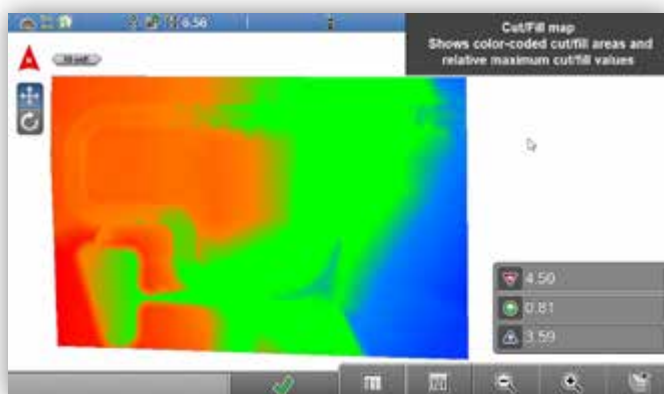

Easy visualization.



See where you are within the design.

GNSS Antenna

A GNSS setup can check rough and fine grade against design files.

Robotic Total Station

Likewise, a total station setup can also check grade against design files.

The Supervisor Solution

Checking grade has never been as easy as riding in your truck. The Supervisor app view gives you measurements from inside your vehicle. Turn any site vehicle into a grade checking solution.



Off-Machine Tools



Leica iCON gps 60 - Smart Antenna

The most rugged GPS in the industry with leading GNSS technology innovations to keep you connected and busy.

- Leica SmartTrack+, SmartCheck+, and Leica xRTK
- Upgradeable satellite networks
- Bridges RTK communication gaps up to 10 minutes.
- Integrated radio, modem, and Bluetooth®
- Integrated NTRIP Server and CASTER for internet-based Reference Station



Leica iCON gps 70T - Smart Antenna

The ultimate GNSS rover and field solution for maximum efficiency.

- The first ever fully functional revolutionary tilting rover. No bubble needed.
- Leica SmartTrack+, SmartCheck+, and Leica xRTK
- Full GNSS with L5 support
- Bridges RTK communication gaps up to 10 minutes.
- Integrated radio, modem, and Bluetooth®
- Integrated NTRIP Server and CASTER for internet-based Reference Station

Leica iCON gps 70 T - Smart Antenna

With the iCON gps 70 T you can measure and stakeout points quicker than ever before without the need to keep the pole vertical and level the bubble. The combination of the latest GNSS technology and inertial measurement unit (IMU) equips the iCON gps 70 T with permanent tilt compensation and makes it resistant to any magnetic interference.

- Permanent tilt compensation increases measurement productivity and reduces human error
- Calibration free and resistant to magnetic interferences
- Intelligent selection to automatically reject reflected or noisy signals
- Intelligent management of multi-frequency and multi-constellation signals
- IP68 protection and can work from -40°F to +149°F
- Increased productivity, safety, and accuracy



Off-Machine Tools



Leica iCON iCR80 - Robotic Construction Total Station

The Leica iCON iCR80 construction total station keeps its 'eye' on only one thing: the user's target. Layout more points per day thanks to ATRplus, the most robust automated-aiming, lock and re-lock technology in the market. The iCR80 is especially useful in congested sites with many distractions, such as reflections, machines and people moving around.

- Faster prism search by patented technology, PowerSearch
- Stable data communication with long-range Bluetooth® (up to 400m)
- Easy hand-over control from pole to machine and vice versa
- ATRplus technology, maximising the total station's ability to remain locked on your target for highest point-to-point layout speed
- "Tune out targets" feature to ignore other distractions in the field
- Fastest re-lock in case of interrupted line of sight



ON-MACHINE SOLUTIONS

Increase accuracy, productivity, and uptime with Leica Geosystems' machine control solutions. With a powerful feature set and real-time designs sent straight to the machine, avoid rework, material waste, and reduce crews needed on site – meaning a safer work zone.



Excavator System



Dozer System



Grader System



Wheel Loader System

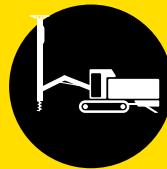

Drilling System



Piling System



Concrete & Asphalt Paving System



Kerb & Gutter System



Milling System



Roller System

3D MACHINE CONTROL PANEL

One Control Panel for All Machines

The new Leica MCP80 can handle all 3D applications in heavy construction. You can easily move your panel from machine to machine no matter the application.

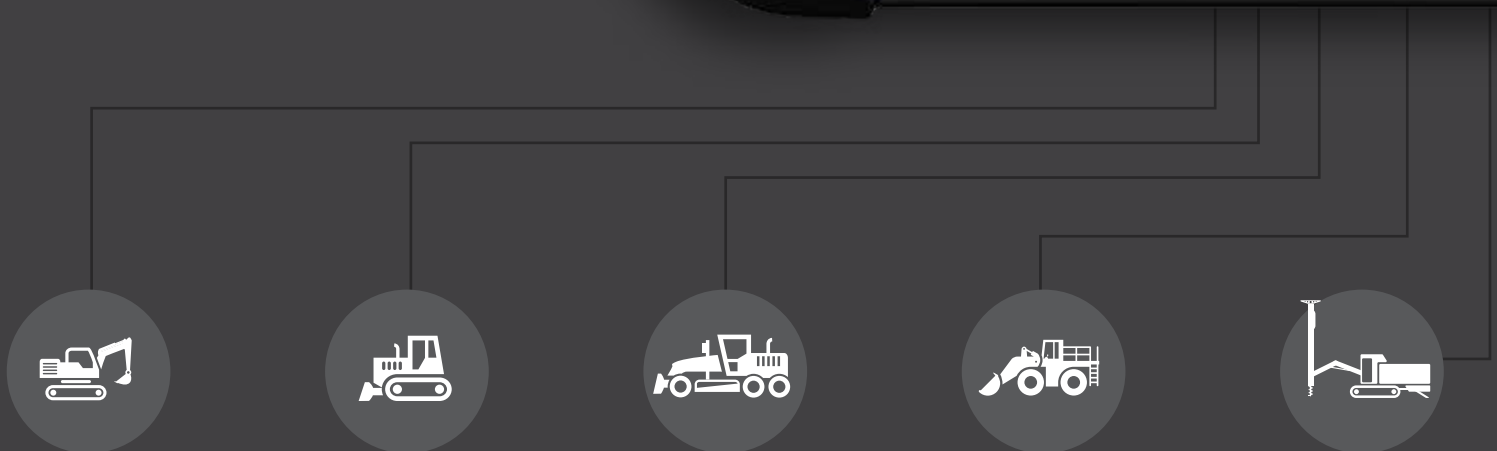

Excavator System



Dozer System



Grader System



Wheel Loader System



Drilling System



- One easy-to-use industry leading interface that is used across all 3D machine control applications.
- Large color touch-screen with backlit buttons.
- You can personalize the panel to your liking and take it with you from one machine to another.



Piling System

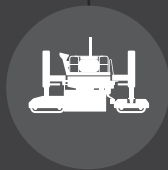

Concrete & Asphalt Paving System



Kerb & Gutter System



Milling System



Roller System

3D MACHINE CONTROL PANEL

Say Hello to The Industry's Smartest Docking Station

The new Leica MDS series in-cabin docking stations will store your calibration values and hydraulic parameters for worry-free machine swapping. These docking stations require no long-winded setups when switching panels. And at an IP67 rating, these are truly the most resilient docking stations for the heavy construction industry.

- Fully cable-free system
- Assures easy removal of panel
- IP67 environmental rating
- One common interface across all 3D machine control applications

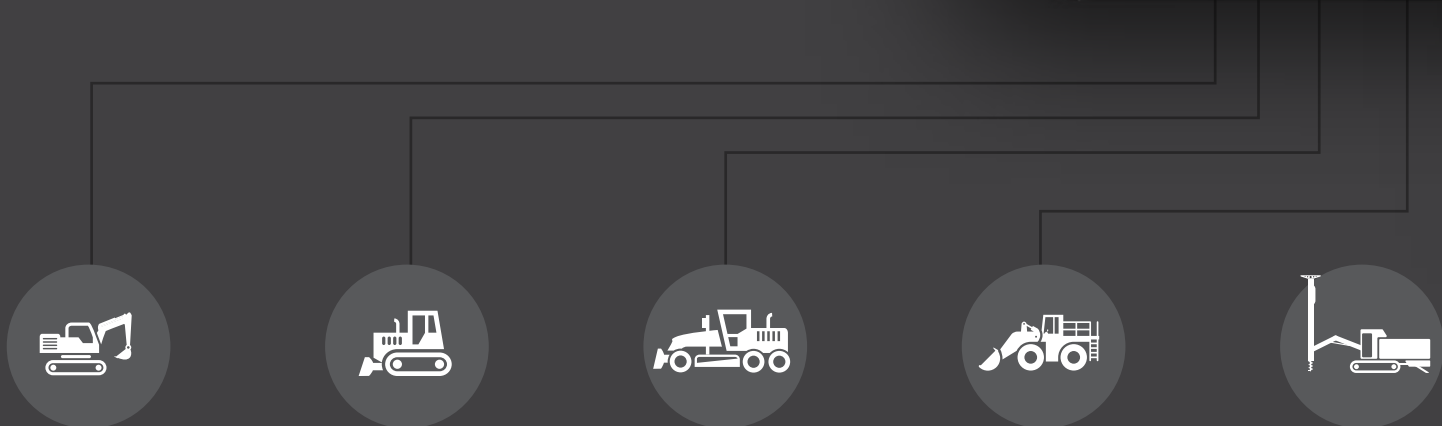

Excavator System

Dozer System

Grader System

Wheel Loader System

Drilling System

QUICK RELEASE



Piling System



Concrete & Asphalt Paving System



Kerb & Gutter System



Milling System



Roller System

2D MACHINE CONTROL PANEL

One panel. Multiple Machines.

Easily swap your panel from machine to machine.

The Leica Machine Control System allows you to easily interchange, customize, and upgrade system components in order to provide you with the most flexible and cost efficient solution on the market today.



AVAILABLE FOR:



Excavator
System



Dozer
System



Grader
System

PowerSnap™ Technology

Use your panel on several machines in your fleet without the hassle of installation. This cable-free configuration allows for simple and fast exchange of panels between different 2D machines. The cradle is installed once and stores machine-specific settings.

- Rapid interchange of control panels between machines
- One cradle for all iCON excavate and iCON 2D grade panels
- Easy removal of core components for overnight security
- Contact and cable-free connection to control/display panels
- Unique patented Snap-On & Snap-Off capability



EXCAVATOR SYSTEM

Achieve precision control for your excavation machines.

From simple slope grading, to blind and submerged cuts, and everything in between, our versatile machine control solutions provide your excavator operators with CAD models right in the cab. The easy-to-operate user interface means your operators can jump on it with little training and get optimal results. Grade check without a surveyor with our robotic total station guidance or our GNSS setup for advanced control. And at the end of the day, the core components snap off for maximum security.



1D System

Leica iCON iXE1

Even for the not so complex excavating tasks, the 1D guidance system provides far superior laser guidance over traditional practices.

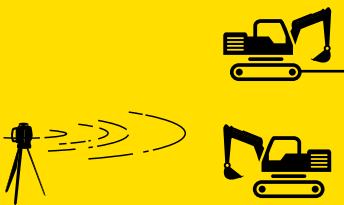

2D System

Leica iCON iXE2

Our 2D system gives the operator high-accuracy dual slope and level control for maximum utilization of your machine from the start.

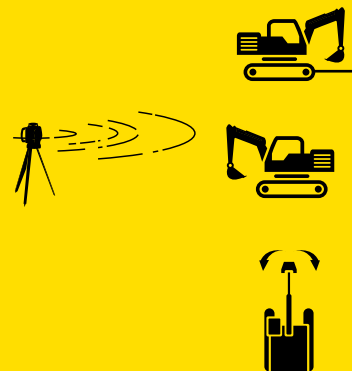

3D System

Leica iCON iXE3

For those who need the ultimate precision guidance, there's the 3D machine control system. Work from 2D and/or 3D digital models for supreme accuracy and the most complex designs.

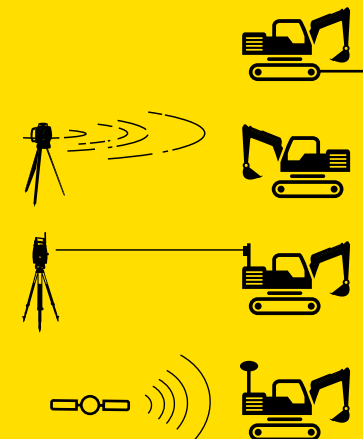



Excavator System Features

1D Systems



DEPTH

Commonly used for basements, foundations, etc.



SLOPE

Set the desired slope for the embankment.



PIPELAYING

Set the desired depth and slope of the pipe trenches.



UNDERWATER WORK

The bucket motion is shown on the graphical display.



GRADING WORK

Set the right depth and the desired tilt in one direction.



LASER REFERENCE

Offers the possibility of using rotating laser as a reference.



GRADIENT

In the longitudinal direction.



HEIGHT ALERT

An audible signal warns the operator if the defined limit is exceeded. Useful around bridges and overhead lines.

2D Systems



DEPTH

Commonly used for basements, foundations, etc.



SLOPE

Set the desired slope for the embankment.



PIPELAYING

Set the desired depth and slope of the pipe trenches.



UNDERWATER WORK

The bucket motion is shown on the graphical display.



GRADING WORK

Set the right depth and the desired tilt in one direction.

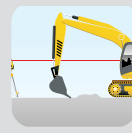

LASER REFERENCE

Offers the possibility of using rotating laser as a reference.



GRADIENT

In the longitudinal direction.

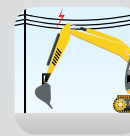

HEIGHT ALERT

An audible signal warns the operator if the defined limit is exceeded. Useful around bridges and overhead lines.



GRADIENT

The system can handle both pitch and roll.



UNDERWATER WORK

The bucket motion is shown in the graphical display.



ROLL

Sensors record and compensate for the machine tilt.



PITCH

Sensors record and compensate for the machine tilt.



COMPASS

The system uses a compass to establish the direction of the tilt and allow for compound slopes.

From 1D to 3D machine control features, our excavator systems cover tasks from simple depth and slope control, to advanced features like auto tilt with CoPilot and even underwater work.

3D Systems



DEPTH

Commonly used for basements, foundations, etc.



HEIGHT ALERT

An audible signal warns the operator if the defined limit is exceeded. Useful around bridges and overhead lines.

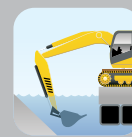

3D/GNSS

Our 3D system enables you to use dual slope in 2D and reference models in 3D.



SLOPE

Set the desired slope for the embankment.



GRADIENT

The system can handle both pitch and roll.



PIPELAYING

Set the desired depth and slope of the pipe trenches.



UNDERWATER WORK

The bucket motion is shown in the graphical display.



2D OR 3D

Switch between the 2D and 3D screens by just pushing a button.



COMPLEX UNDERWATER WORK

The bucket motion is shown on the graphical display.



ROLL

Sensors record and compensate for the machine tilt.



GRADING WORK

Set the right depth and the desired tilt in one direction.



PITCH

Sensors record and compensate for the machine tilt.



ROBOTIC TOTAL STATION CONTROL

Use a robotic total station as a reference.



LASER REFERENCE

Offers the possibility of using rotating laser as a reference.

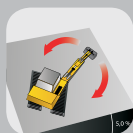

COMPASS

The system uses a compass to establish the direction of the tilt and allow for compound slopes.



GRADIENT

In the longitudinal direction.

EXCAVATOR - 2D SYSTEM

Leica iCON iXE2

Single/dual slope and depth control



This multifunctional 2D control system is designed to make excavating easier and more productive. It allows multiple elevations and slopes to be constructed, at any orientation, without resetting the machine or laser height reference.

The Leica iCON excavate iXE2 displays the bucket's actual position relative to design elevation and slope, allowing you to reach the design grade faster. And if you want more out of your excavator, you can start with single grade operation and upgrade as needed to a full dual grade system by adding a rotation and tilt bucket sensor to your system. With an additional 3D control box and GNSS sensors, you get a high efficient 3D guidance solution that allows you to excavate according to the 3D design model on your panel.

Related Products:

- Rugby lasers

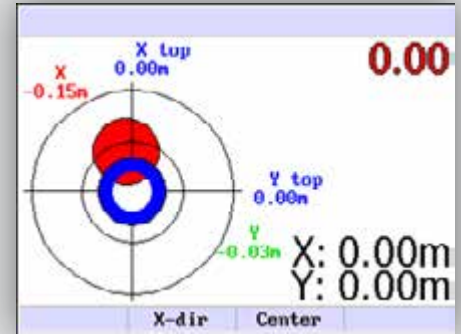

Runscreens with guidance for a drill tool

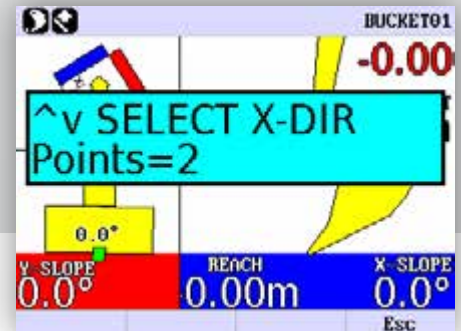

Setting compass direction either in machine direction or calculated from 2 points

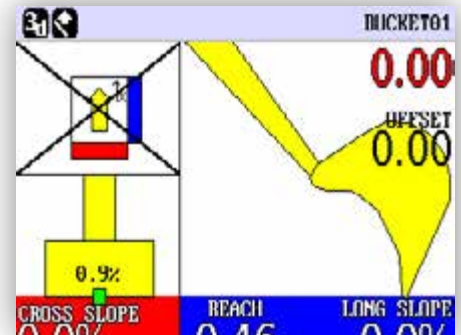

Runscreens view without dual slope (Compass disabled)

- Upgrade to 3D by adding a GNSS receiver and 3D control panel.
- High-accuracy dual slope and level control via the rotation sensor
- Real-time cut/fill indication on the graphic display
- No grade checking needed
- No more over excavations

2D EXCAVATOR SYSTEM Components

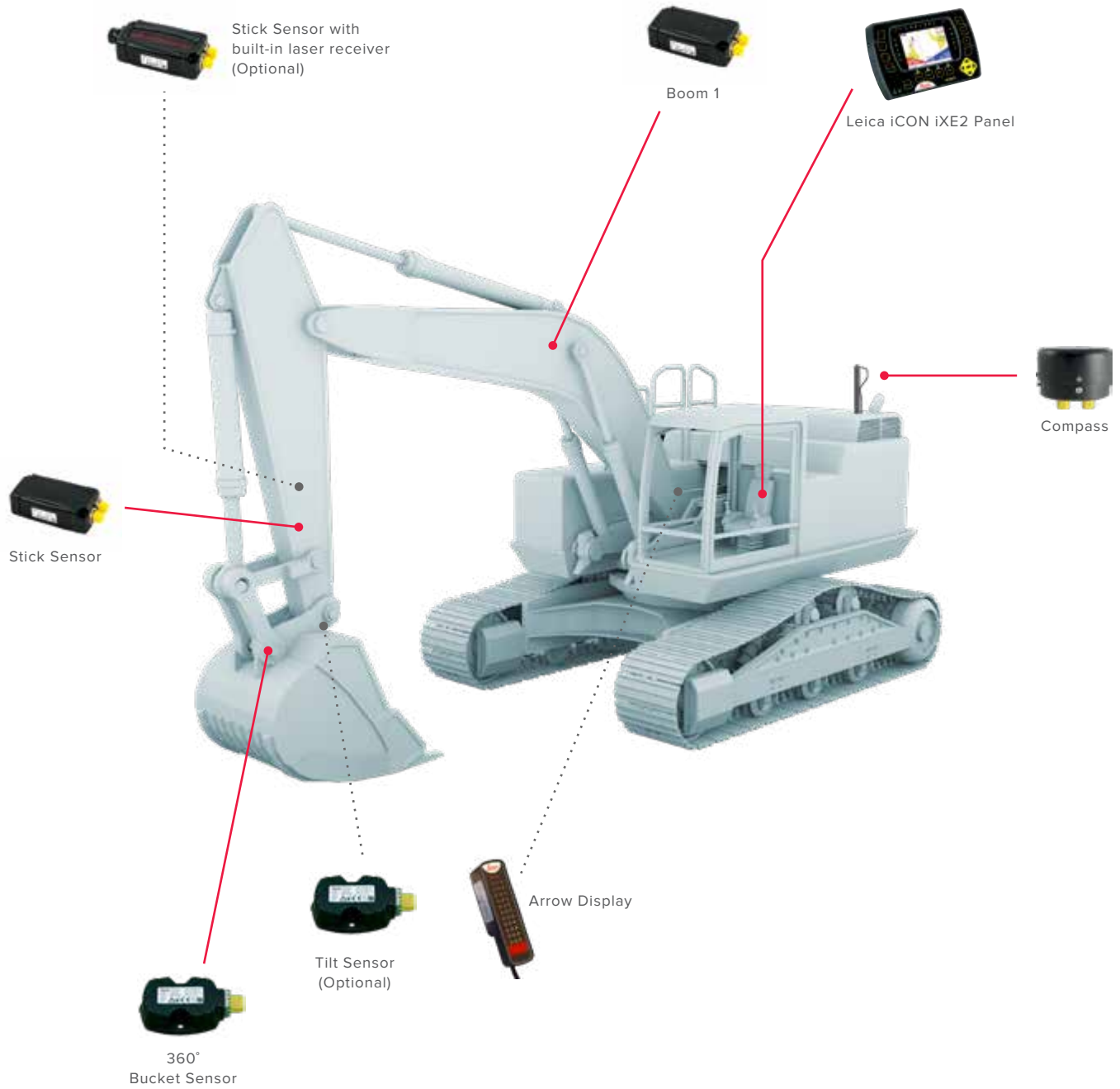

EXCAVATOR - 3D SYSTEM

Leica iCON iXE3

Full 3D and 2D control of your excavator.



The iXE3 machine control system works with dual grade functions in 2D, as well as reference models and GNSS in 3D. And with the optional CoPilot feature, you can concentrate on digging with automatic bucket slope control.

The iXE3 system uses 3D design (CAD) models and state of the art GNSS technology to guide the operator. Design information and real-time cut/fill indications are displayed in the cab on your control panel, allowing you to rapidly excavate to the reference design – eliminating the need for batter rails, boards and string lines, and ultimately grade checking. The data from the panel can be sent straight back to the office for direct monitoring.

- Work directly from CAD models.
- Switch between 2D/3D with the touch of a button
- Create simple terrain models directly on the screen
- Eliminate over excavation and costly material overruns
- Full guidance with rich 3D graphics
- No repeated laser setup and error potential

Related Products:

- Leica iCON gps 60/70T
- Leica iCON iCR 80



Optimize views to operators preference

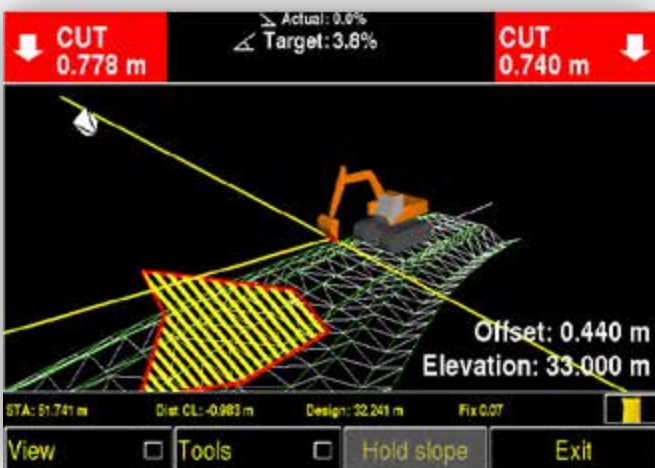

Use exclusion zones to prevent digging in unsafe areas

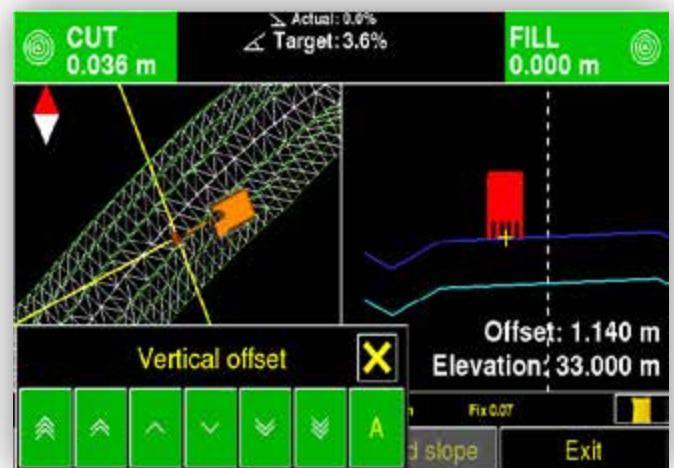

Easily adjust offsets on-the-fly

3D EXCAVATOR SYSTEM Components

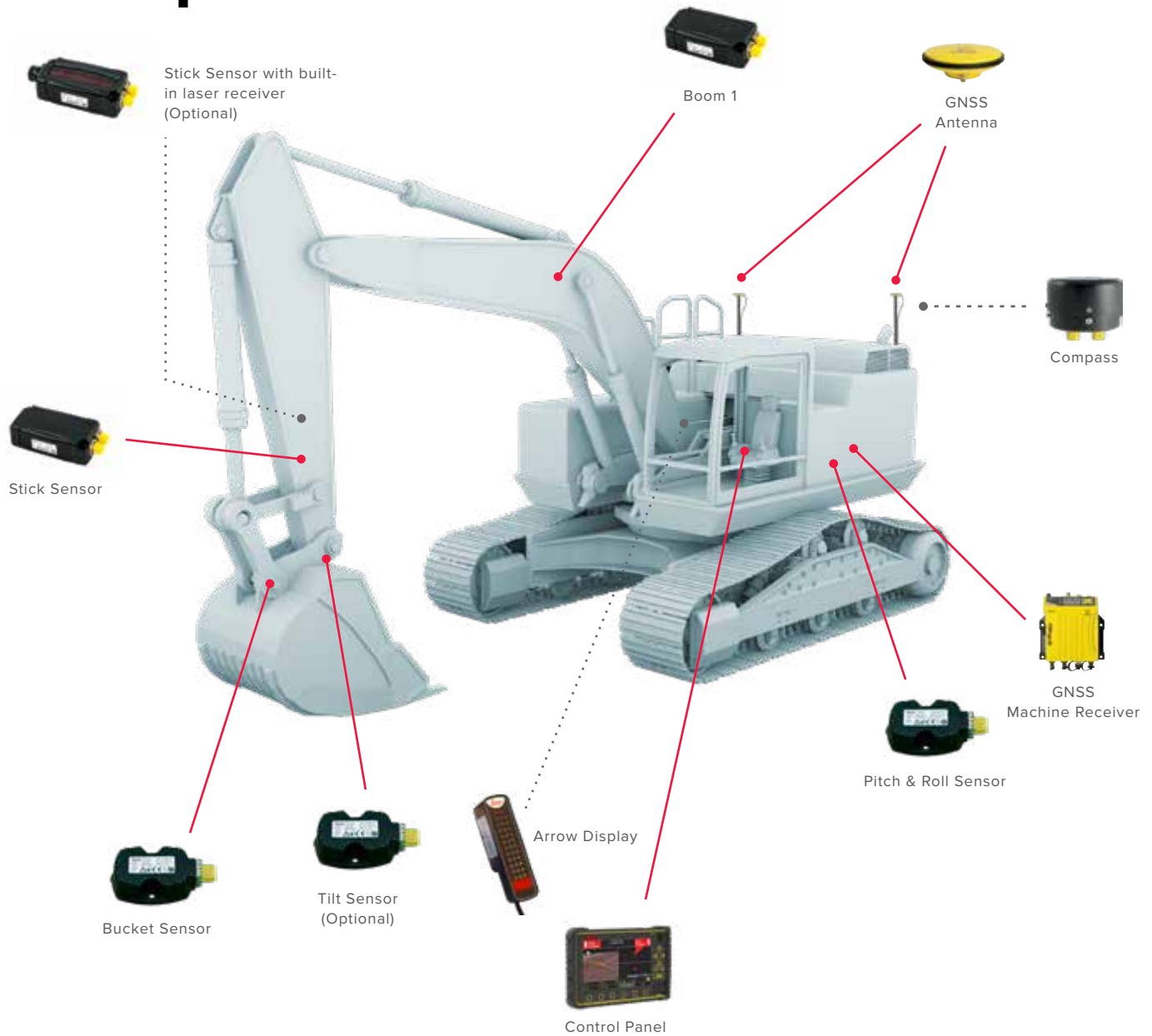

OPTION 2

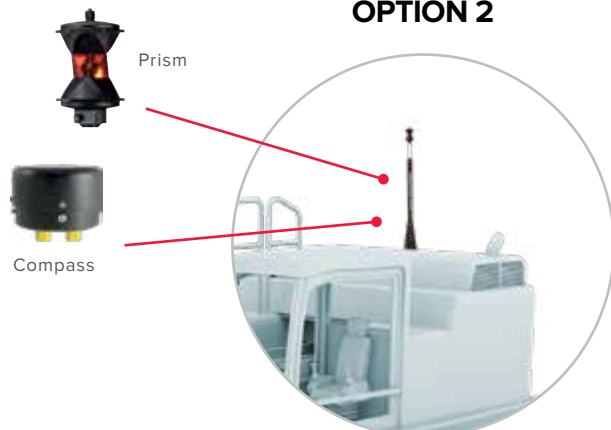

EXCAVATOR - AUTOMATION

iXE CoPilot

Automatic tilt rotator control.



The CoPilot upgrade for the 2D and 3D excavator system puts the power of tilt and roto-tilt buckets into everyone's hands, regardless of experience level.

- Auto tilt automatically adjusts the reference model's surface under the bucket and the operator adjusts to the reference model surface under the bucket, allowing the operator to concentrate on performing the excavation
- Eliminates the constant manual adjustment of the slope of the bucket
- Easy to learn no matter the training level
- Enable copilot at the touch of a button

DOZER SYSTEM

Ultimate flexibility for your earthmoving tasks.

AUTOMATIC MODE

Run machines in automatic mode and keep precision without needing to rework areas.

NO REPEAT PASSES

Maximize your dozer's performance by angling the blade and control windows more effectively. No need to repeat passes over the same area to remove dirt build up.

SCALABLE

The scalable iCON grade solution lets you expand your dozer's system as your projects grow in scope and size. You only invest in what you need.

SPEED

iGD4SP delivers unequalled speed and precision, and helps provide maximum productivity with higher profit.

SMALL DIAMETER MASTS

Get easier operation with clear visibility of the blade's working area.

QUICK RELEASE

Use of the same panel for any level of functionality. Purchase licenses only for the configurations you need and only for the functionality you want.

CAN

The latest CAN technology lets you expand the functionality of your system by simply adding the required components.

2D DOZER SYSTEM Components

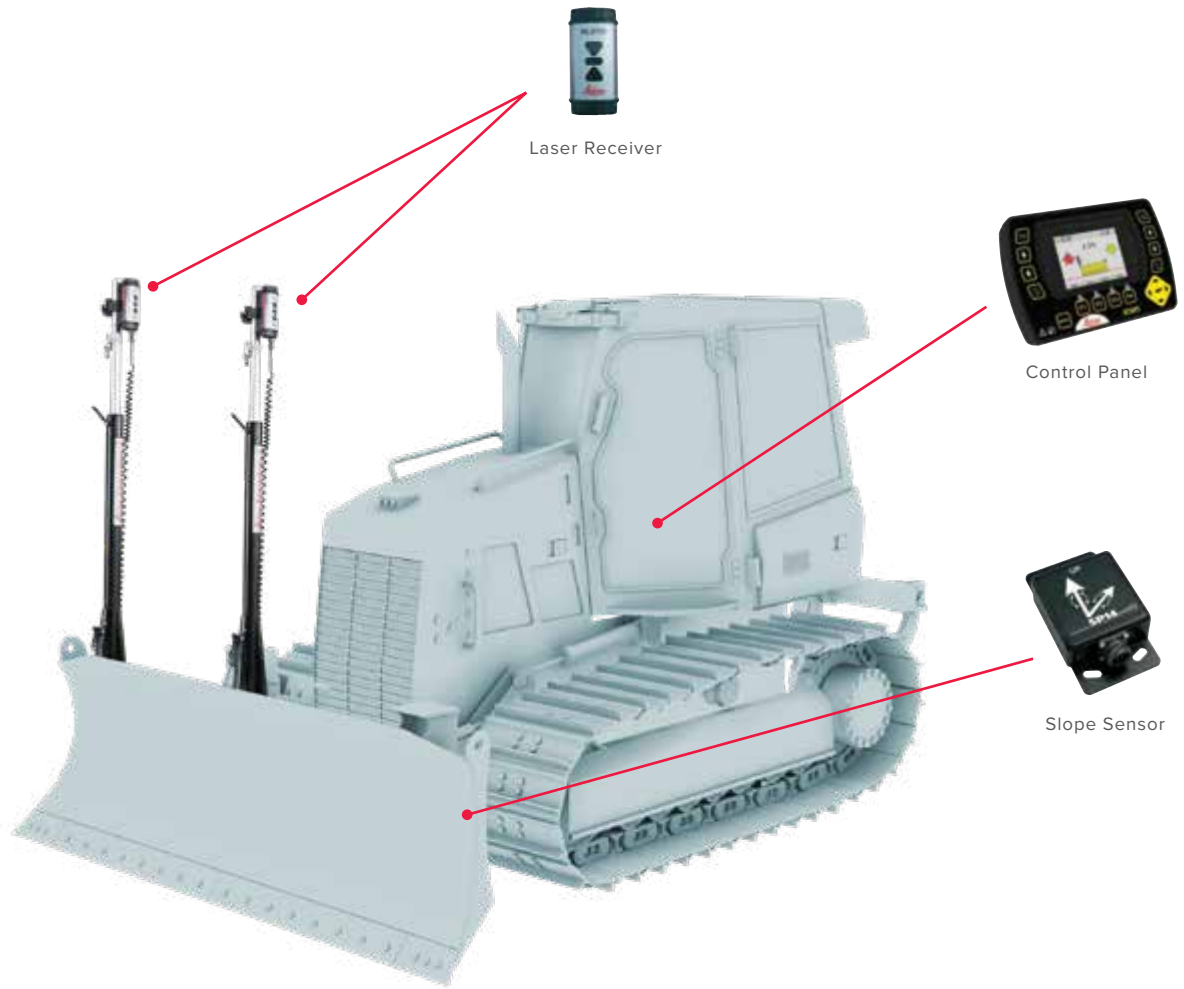

OPTION 2

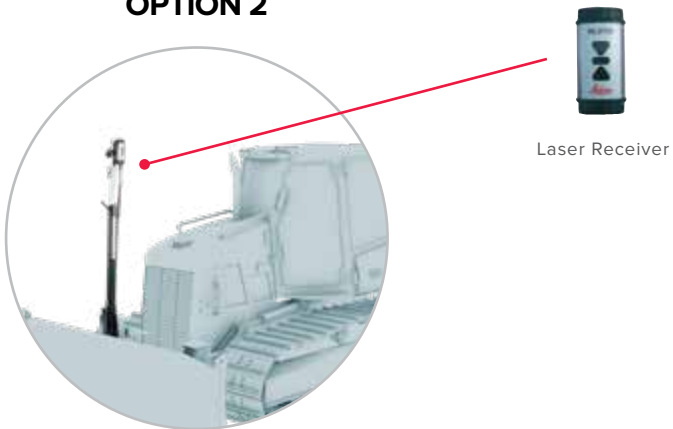

DOZER - 2D SYSTEM

Leica iCON iGD2

Easy-to-use, yet powerful 2D dozer machine control



AUTOMATIC TILT FUNCTION

Be in permanent control over the bulldozer blade. The MSS130x inclinometer sensor is mounted on the machine to detect the tilt of the blade.



AUTOMATIC HEIGHT FUNCTION

The laser receivers have a capture angle of 360 degrees. The MLS720 laser receiver is mounted on the mast for obtaining height. iGD2 can be installed with either single or dual laser receivers.

The Leica iCON iGD2 dozer system provides automatic control of both slope and elevation. When using two masts and laser sensors, you can work independently of slope direction.

Leica iCON iGD2 system for dozers can dramatically increase machine utilization, boost productivity and optimize material usage on any earthmoving and fine-grading contract. It can be used with a wide range of sensors and combines ease of use and unrivaled flexibility with a very powerful and intuitive user interface.

- Dedicated grade and slope adjustment keys
- Intuitive graphics show the blade's actual position
- Quick and easy setup for operator preferences
- Auto/Manual control mode selection
- Fully waterproof system

Related Products:

- Rugby lasers

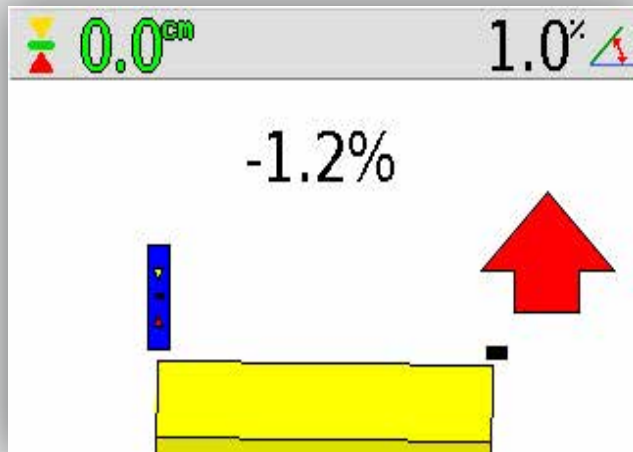

Laser and cross slope

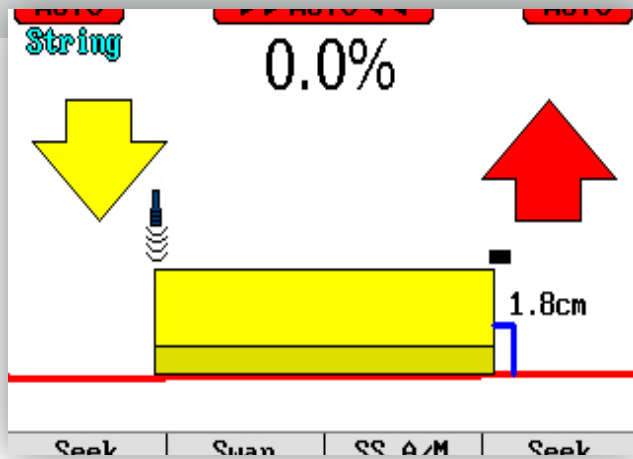
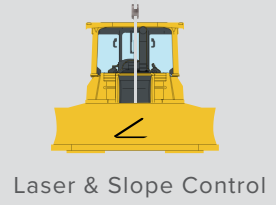

Sonic and cross slope

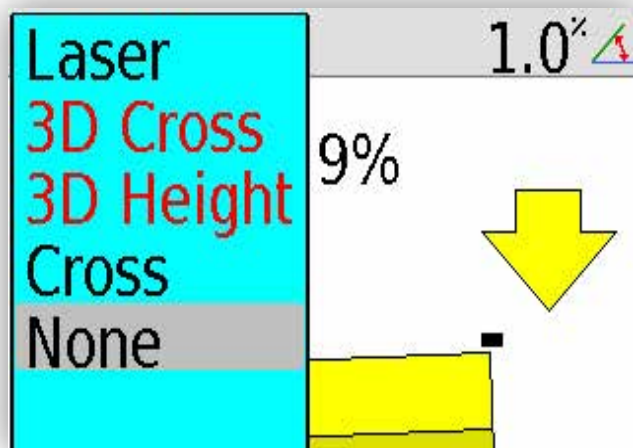
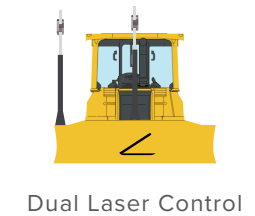
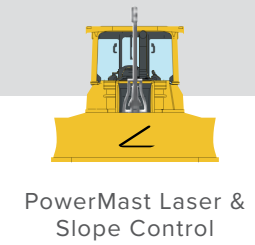

Multiple sensor options



DOZER - AUTOMATION

Leica iGD2 CoPilot

Automatic cut/fill control on your dozer.

The iGD2 CoPilot software upgrade allows the dozer operator to grade to specification, regardless of their training level. It automatically adjusts critical parameters for more accurate grading results. Make straight, smooth pushes without any waves on all your grading or material moving tasks.

- Ensures correct grades without washboard surfaces
- Works without a rotating laser, total station, or GNSS
- Less rework, wear and tear, and training effort
- Provides a safer work environment.
- Works with 2D

Simplify

Make the use of dozers easy even without 2D or 3D machine control.

Empower

Improve the productivity of less experienced operators and decrease fatigue and stress on all jobs. Operators simply start the machine and go, regardless of training level.

Expand

Use the Leica iGD2 CoPilot on an existing iGD2 solution or a new installation for the maximum flexibility.







3D DOZER SYSTEM Components

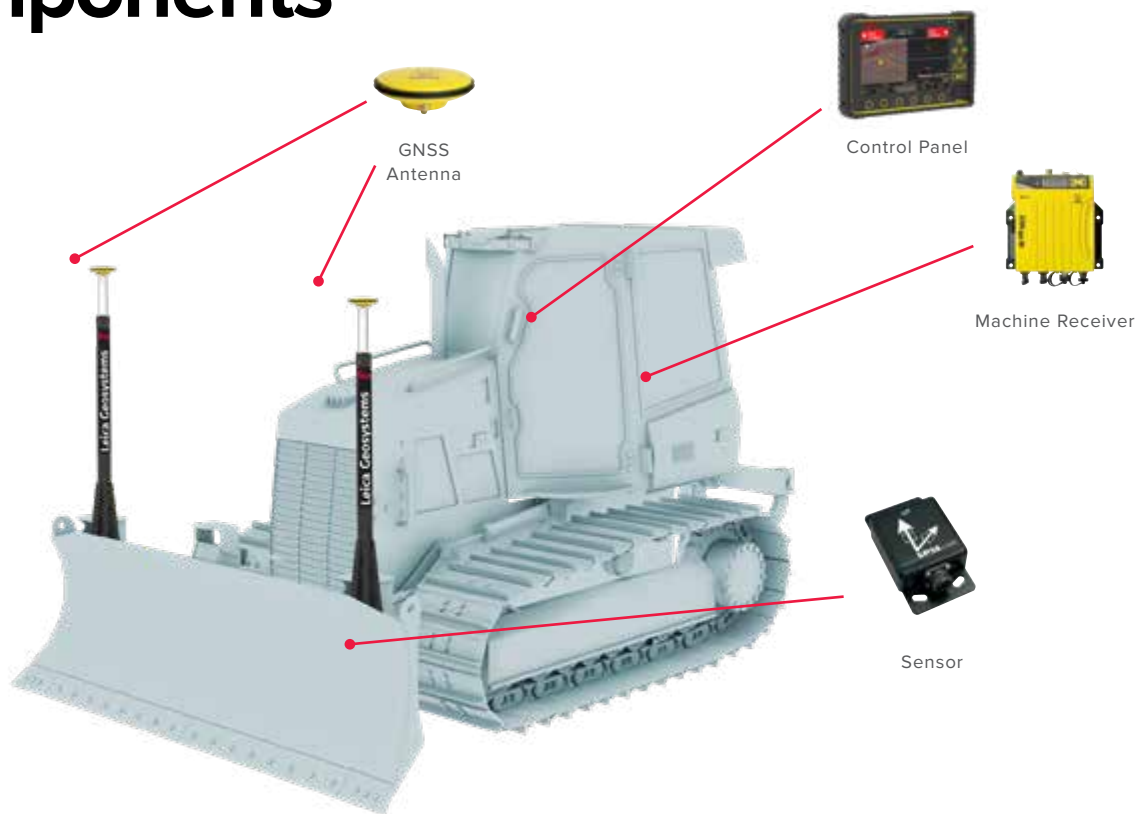

OPTION 2



Prism



OPTION 3



GNSS Antenna



OPTION 4



GNSS Antenna

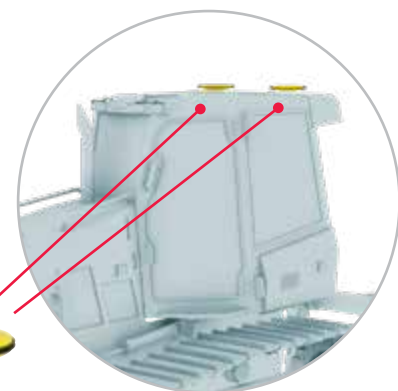

Dual GNSS Configuration

iGD4^{SP} is ideal for bulldozers with six-way (PAT) blades. Having a second GNSS antenna on the blade will improve the accuracies your bulldozer can achieve when working in very demanding environments such as steep slopes with the blade fully angled.

DOZER - 3D SYSTEM

Leica iCON iGD3/iGD4^{SP}

Intelligent 3D grading solution for dozers



The iGD3 3D dozer system opens new dimensions in earthmoving and fine grading. It brings the design surfaces and alignments inside the cab. Work independently and accurately anywhere on the project design, guided by GNSS or total station.

The Leica iCON grade iGD3 system can dramatically increase machine utilization and productivity and optimize material usage on any earthmoving and fine-grading contract. It can be used with a wide range of sensors and combines ease-of-use with unrivalled flexibility and a powerful and intuitive user interface.

- User-selectable views (e.g. Plan View, Cut & Fill View)
- Visible display screen, even in sunlight.
- iGD3 remembers all of your settings
- Scalable from 2D to full 3D capability
- Create a reference surface with up to four slopes

Related Products:

- Leica iCON gps 60/70
- Leica iCON iCR 80



Pan and cross section view

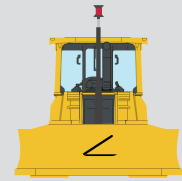

Total Station Control

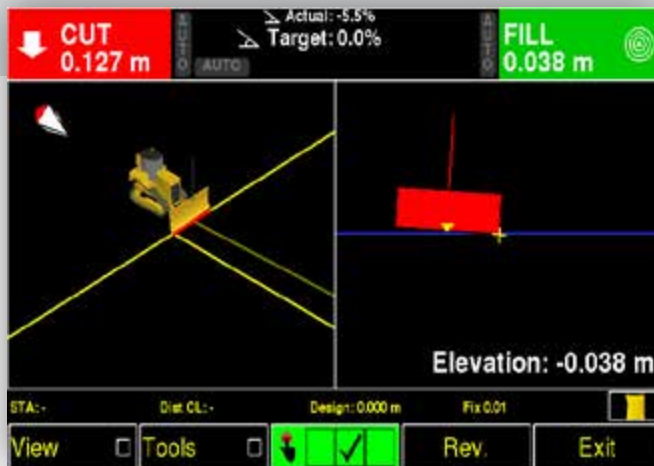

3D and cross section view

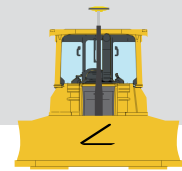

Single GNSS & Slope Control

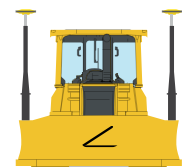

Dual GNSS & Slope Control

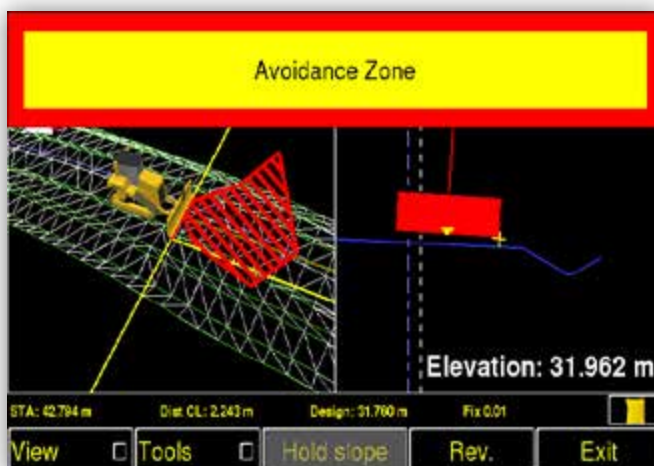

3D, cross section and avoidance

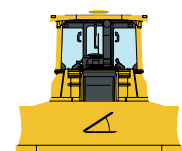

Dual GNSS On-Cab Configuration

DOZER - 3D SYSTEM

Six-Way-Blade

Upgrade to Leica SP Technology to Achieve Maximum Control with Six-Way-Blade Machines

The SP14 sensor provides inertial guidance and generates five times faster hydraulic control. Operators can work through momentary lapses in satellite coverage or lost signal for maximum uptime. Together with our intelligent control panels the results are smoother, more accurate grading at blazing fast speeds.

- Fine grade with your bulldozer in top gear
- Achieve the highest precision at the fastest speed
- Get faster results without losing accuracy
- Gain unmatched productivity that boosts your profitability



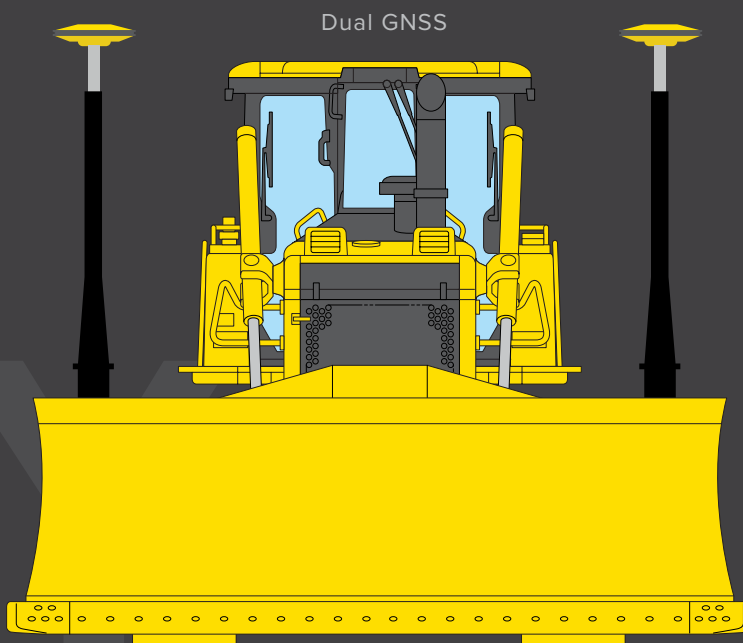

Now you can also use your dozer for fine grading applications and final trim, similar to how you would use your motorgrader. The six-way-blades (PAT) solution provides exact calculation of blade tilt and angle to move dirt from pass to pass more precisely and efficiently, allowing you to finish your jobs in less time with less rework.

- Run machines in automatic mode
- Angle the blade and control windrows more effectively
- The small diameter masts improve visibility of the blade's working area.
- The latest CAN technology lets you expand the functionality of your system by simply adding the required components.

GRADER SYSTEM

Automated control for your motor graders.

MAXIMIZE THE POTENTIAL

Achieve a wider range of applications with higher accuracy.

IMPROVE QUALITY THROUGH AUTOMATION

Run your machine in automatic mode, while moving with precision in any direction.

INCREASE PRODUCTIVITY AND EFFICIENCY

The dual antenna configuration enhances accuracy, resulting in less rework.

PERFORM COMPLEX TASKS WITH EASE

Crab walk your motor grader to properly handle material windrows and precisely grade side slopes or create ditches.

ONLY INVEST IN WHAT YOU NEED

The scalable iCON grade solution lets you expand your grader's system as your projects grow in scope and size.

GROW AS YOU GO

The latest CAN technology lets you expand your system's functionality by simply adding the required components.

TAKE IT WITH YOU

Quick Release lets you use the same panel for any functionality level on any machine supported by iCON 3D.

2D GRADER SYSTEM Components

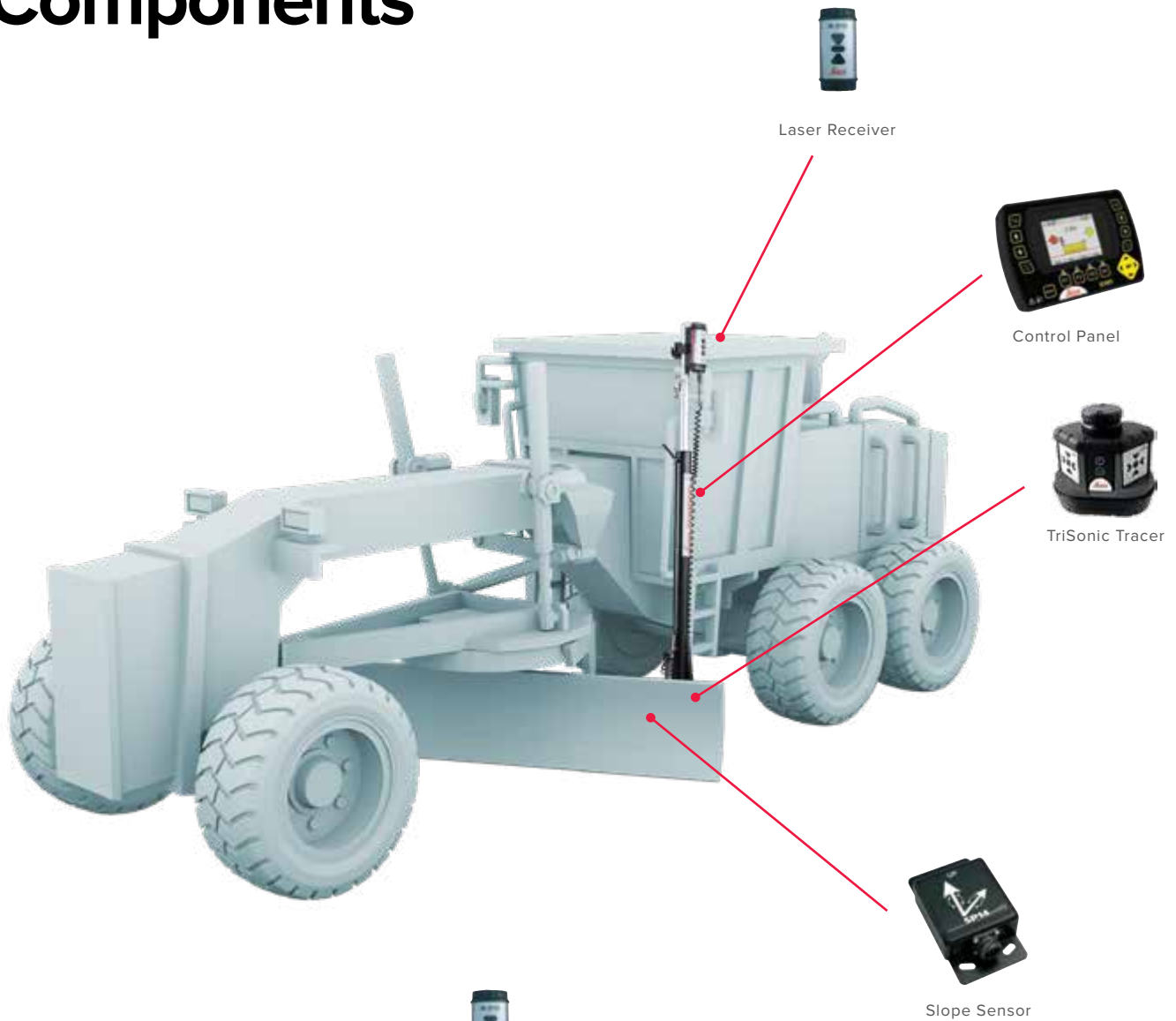

OPTION 2

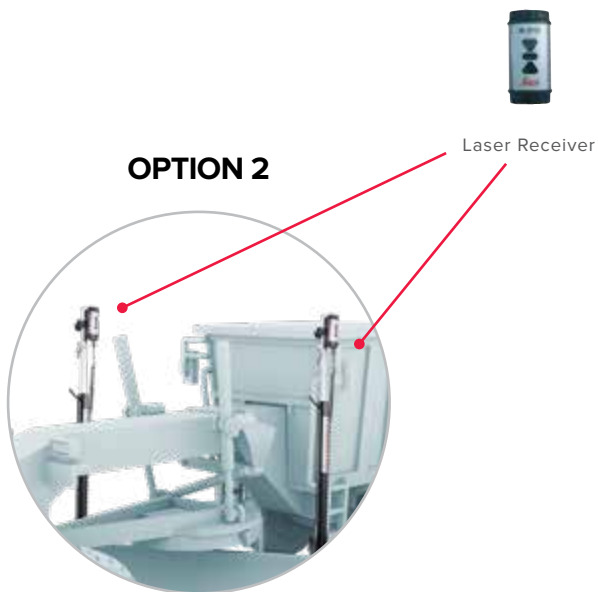

GRADER - 2D SYSTEM

Leica iCON iGG2

Scalable 2D entry system



The iGG2 provides automatic control of both slope and elevation. When using two masts and laser sensors, you can work independent of slope direction. Get to the grade faster than before.

The Leica iCON grade solutions for motor graders offer new site preparation possibilities. The system regulates the elevation and cross slope by means of robust and high-tech sensors. The system helps you improve your productivity as well as save material costs.

- Easy-to-use graphical display – the same panel is used on your dozer and grader, giving you the ultimate in equipment flexibility
- Short learning curve thanks to intuitive software
- The wireless cradle makes it easy to place and remove the panel from the cabin

Related Products:

- Rugby lasers

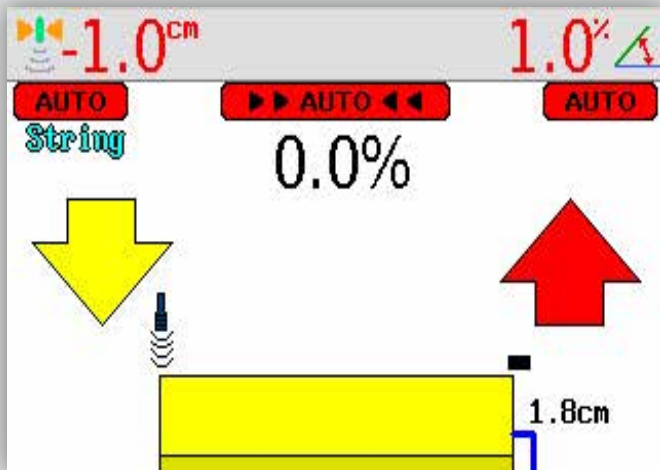

Sonic with automatic side shift to string or kerb and cross slope

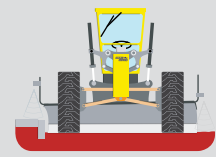

Sonic Tracer System

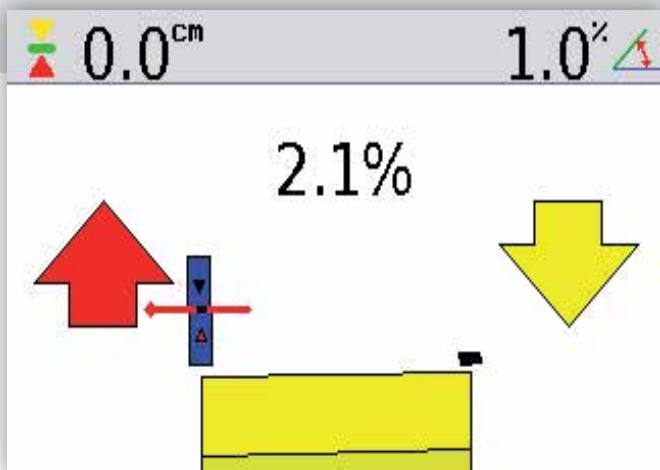

Laser and cross slope

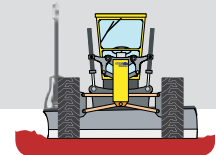

Single PowerMast System

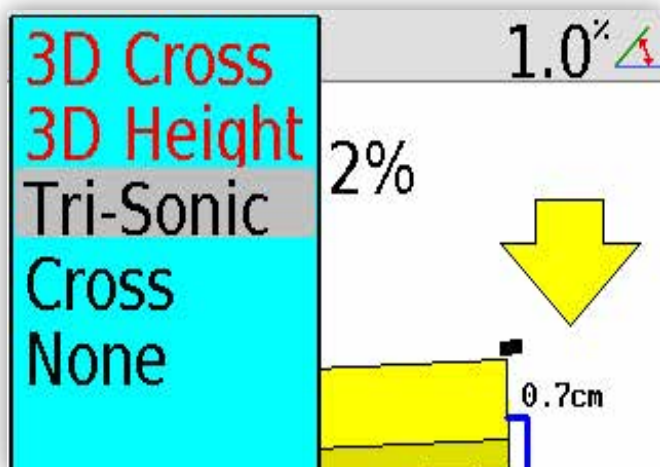

Multiple sensors option

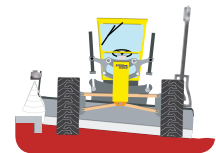

Sonic Tracer & PowerMast Laser Control System

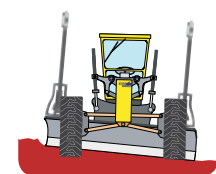

Dual PowerMast System



3D GRADER SYSTEM Components

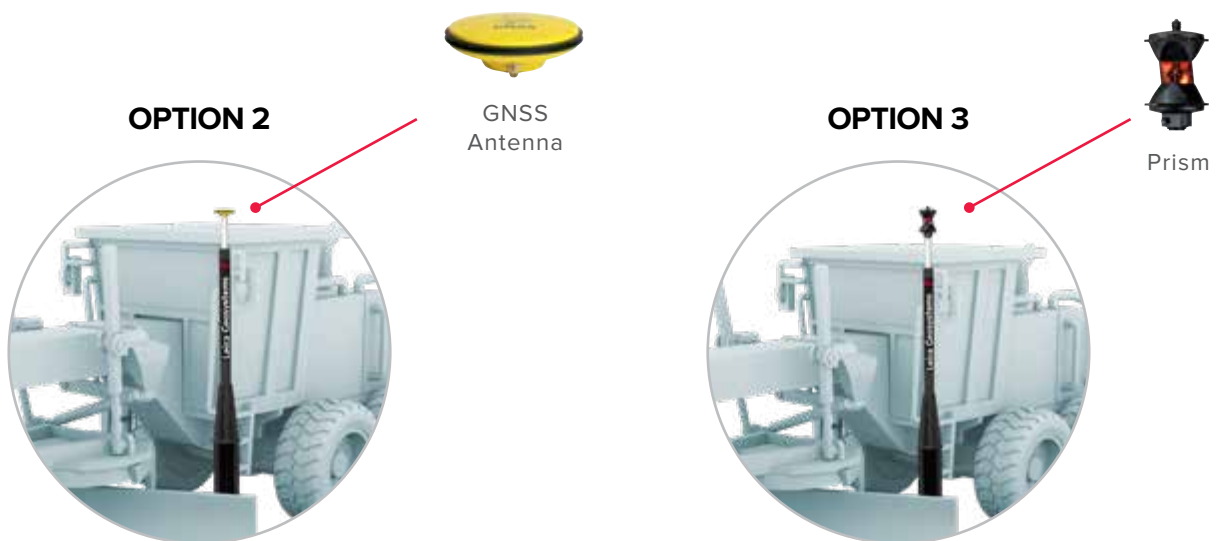
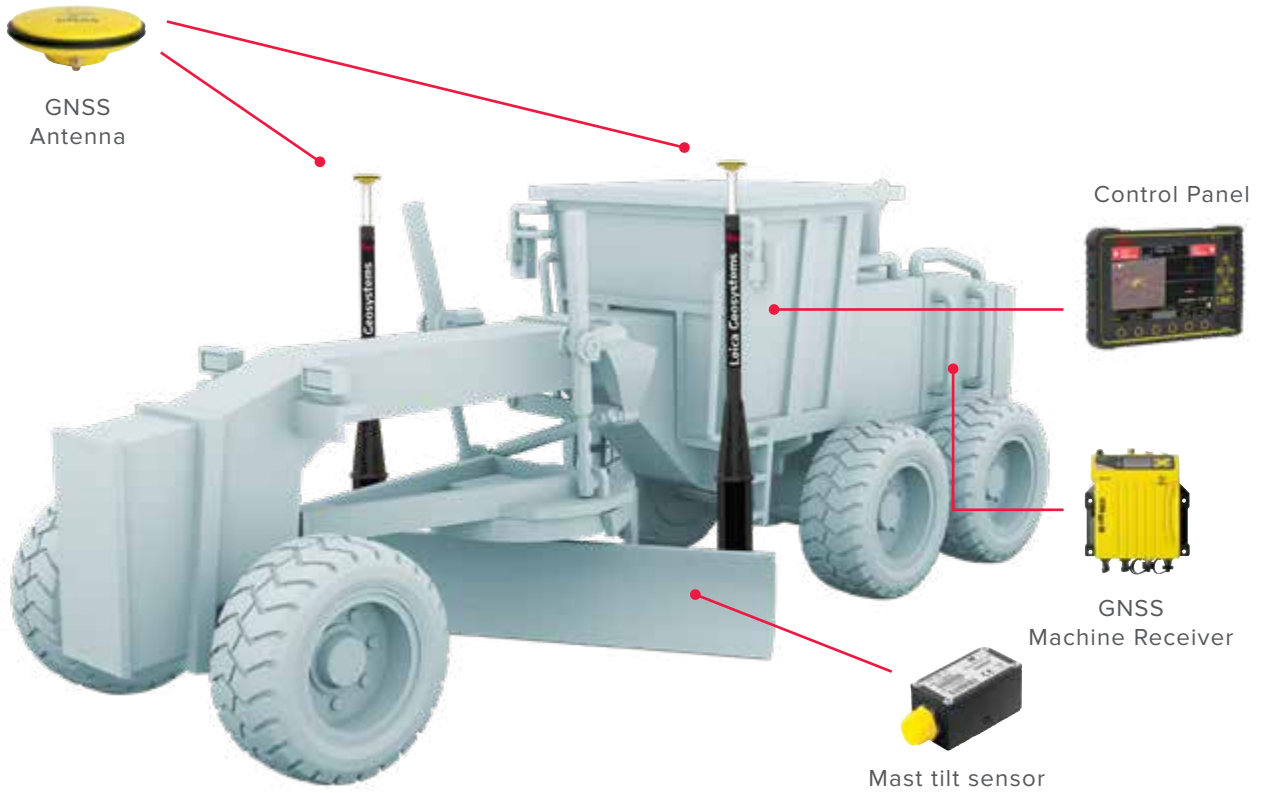

GRADER - 3D SYSTEM

Leica iCON iGG3/iGG4

Flexible machine control solution for motor graders



Optimize material usage on any earthmoving and fine-grading contract with the iGG3. Bring the design surfaces and alignments virtually in the cab – breaking you free from stakes or hubs.

The most efficient and flexible solution for complete automatic motorgrader control, the Leica iCON iGG3 delivers millimeter-accurate control of the blade, which is ideal for all fine grading applications.

- User definable views (e.g. Plan View, Cut & Fill View)
- Visible display screen, even in sunlight
- Leica ConX services fully integrated
- Automatic control of blade side shift
- Unique mast-tilt compensation
- Sideshift functionality

Related Products:

- Leica iCON gps 60/70
- Leica iCON iCR 80
- Leica ConX

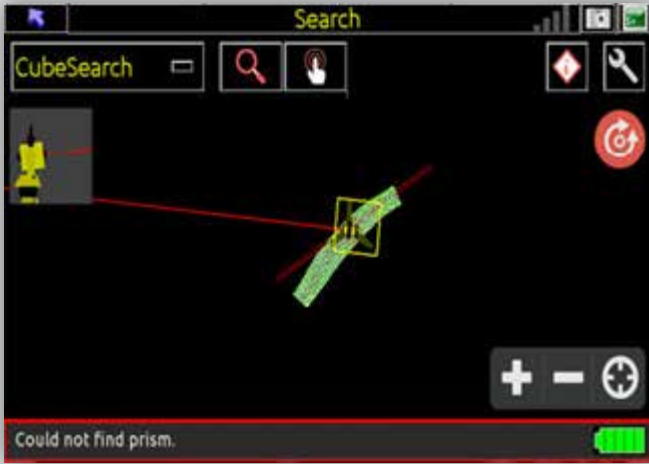

Cube search prism

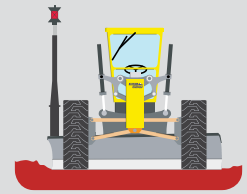

Total Station

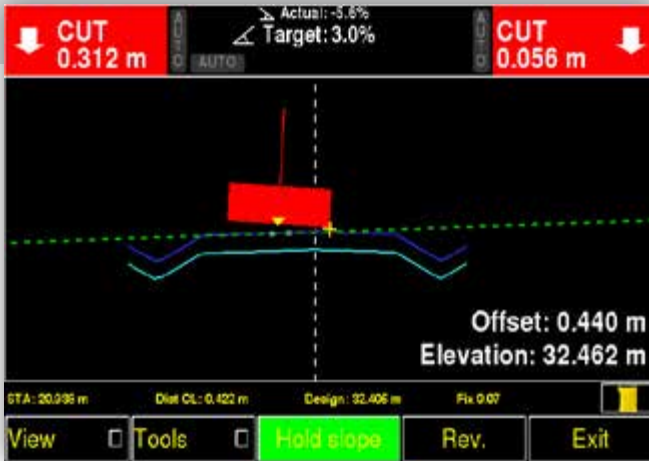

Lock slope

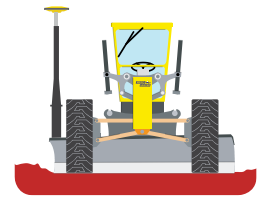

GNSS System

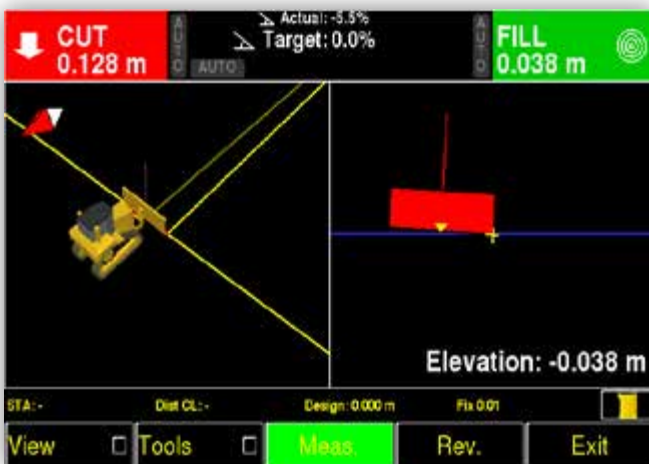

Store points

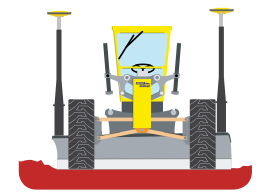

Dual GNSS & Slope Control

GRADER - 3D SYSTEM

Dual Mast

Unlock the Power of Dual Mast with Unrivaled Control for Your Motor Grader

The iGG4 machine control system for motor graders automatically controls the blade while you focus on putting the machine in the optimal position. It watches both ends of the blade for you so you can focus on maneuvering.

- Auto/Manual information directly on screen
- User definable views (e.g. Plan View, Cut & Fill View)
- Visible display screen, even in sunlight
- Expand your system simply by adding components



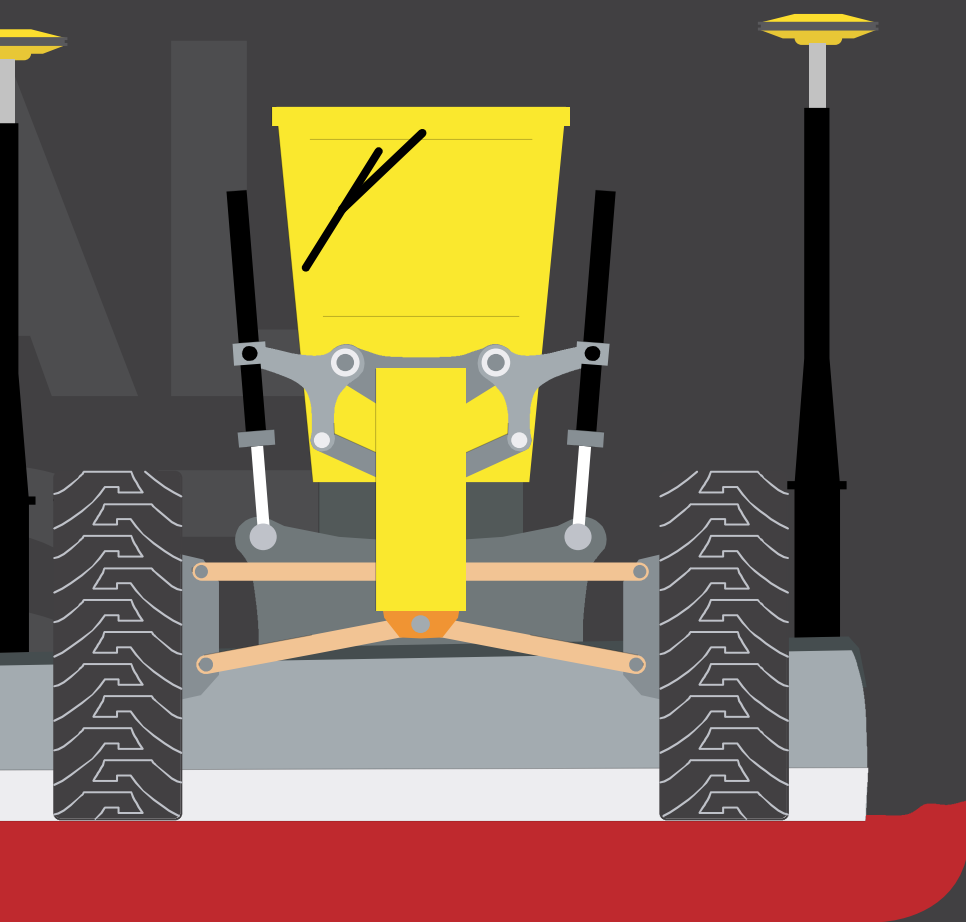

- Maximize the potential of your motor grader for a wider range of applications with higher accuracy.
- Run your machine in automatic mode, while moving with precision in any direction.
- Increase productivity and efficiency with your grader. The dual antenna configuration enhances accuracy, resulting in less rework.
- Complex tasks like articulating the grader and front wheel lean can easily be done thanks to the dual mast.
- The scalable iCON grade solution lets you expand your grader's system as your projects grow in scope and size. You only invest in what you need.
- The latest CAN technology lets you expand your system's functionality by simply adding the required components.
- PowerSnap: same panel use for any functionality level on any machine supported by iCON 3D.

WHEEL LOADER SYSTEM



MAXIMIZE YOUR ROI

Maximize your machine utilisation and return on investment from day one - get the grade right from the start

INCREASE EFFICIENCY

Eliminate over excavation and costly material overruns

OPTIMIZE FLEXIBILITY

Leica Geosystems' unique PowerSnap functionality allows rapid interchange of control panels between machines

REDUCE LABOR COSTS

This is done by decreasing or eliminating grade checks

LEARN AND GO

Operator-friendly user interface reduces training time and cost

KEEP WORKFLOWS SIMPLE

The system provides additional confidence and high productivity

INTEGRATE TELEMATICS FOR COMPLETE CONTROL

Full support of iCON telematics services

WHEEL LOADER SYSTEM Components

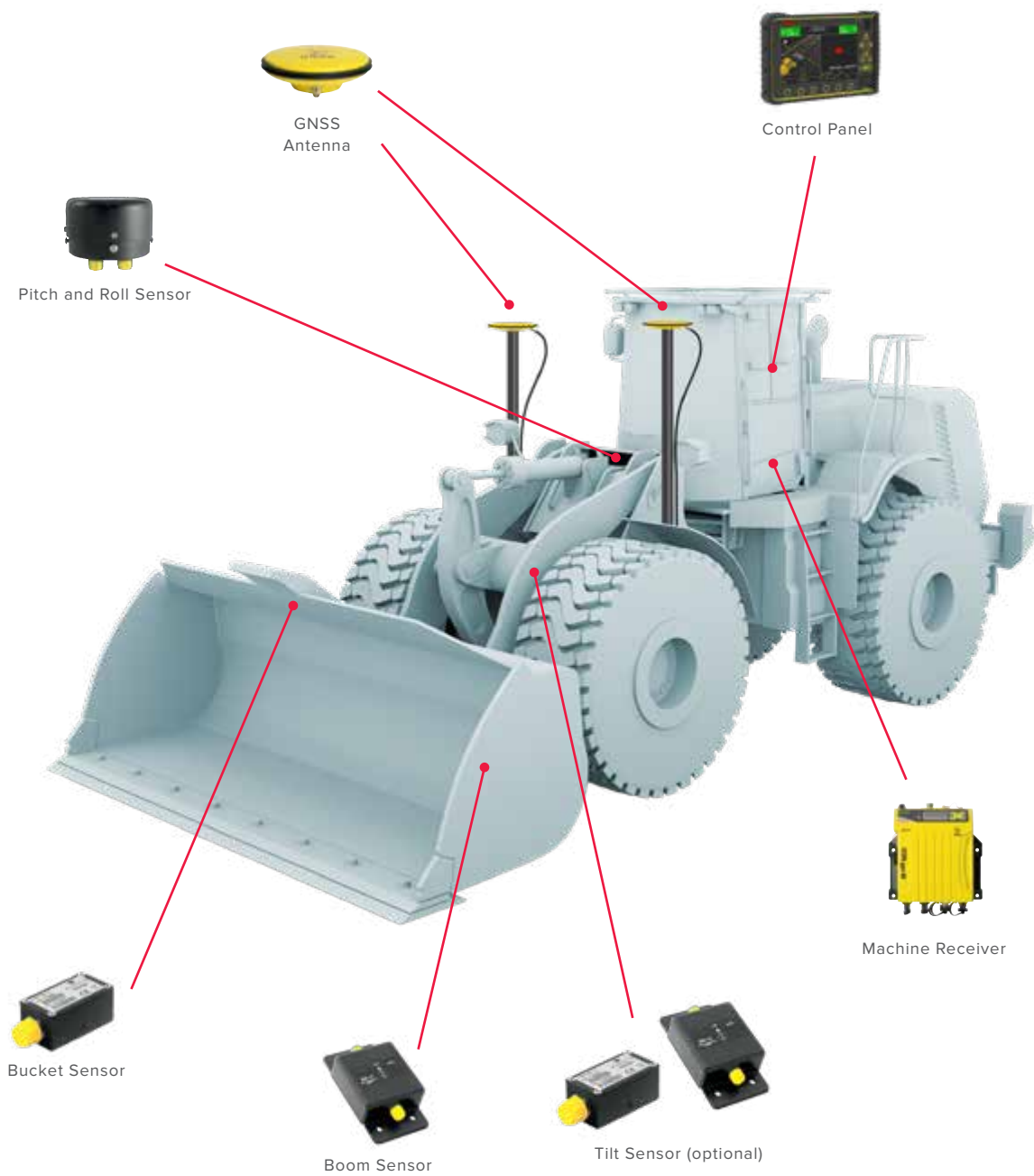

WHEEL LOADER - 3D SYSTEM

Leica iCON iGW3

Intelligent system for wheel loaders.



The iGW3 system brings machine control to your wheel loader. Know the position of the bucket at any time, while working from real-time cut/fill indications displayed on the control panel.

The Leica iCON grade iGW3 wheel loader system provides the real-time positioning of the bucket, allowing the operator to apply instantaneous adjustments of the bucket position. The system uses 3D design (CAD) models and state-of-the-art GNSS technology. Design information and real-time cut and fill indications are displayed on the control panel in the cab for easy and productive operation. The user-friendly interface with graphical color display provides full guidance and allows easy operation.

Related Products:

- Leica ConX

- Maximize your machine utilization and return on investment from day one - get the grade right from the start
- Eliminate over excavation and costly material overruns
- Operator-friendly user interface reduces training time and cost
- Intuitive user interface provides additional confidence and high productivity
- Reduces labor costs by decreasing or eliminating grade checks

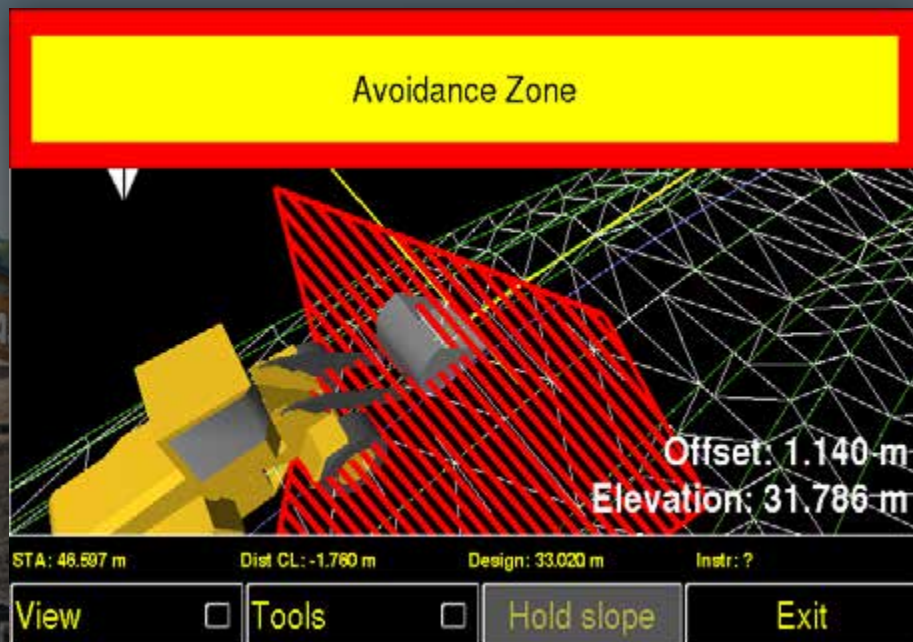

Avoidance zone



Auto logging manual mode



Vertical and parallel height offset

Compact Machine Systems

The ultimate upgrade for your skid steer.

Take your skid steer to the next level by utilizing Leica Geosystems machine control. Its intuitive interface and fully graphical display help your operator get to grade the first time. Connect with lasers, GNSS, or total stations, and easily upgrade from a 2D system to a full 3D system just by adding the right components.



2D COMPACT MACHINE SYSTEM

Leica iCON iGSS2

Flexibility and control for your skid steer



The Leica iGSS2 2D Compact Machine System gives your machine powerful guidance on any earthmoving and fine-grading jobs. Its unrivaled flexibility and powerful and intuitive interface makes grading a breeze.

Leica iCON grade for skid steers is the ultimate tool for box blades. This flexible system can be used for push blades mounted to a skid steer or drag boxes mounted to a skip loader. Single or dual laser configurations allow for height control only or height plus cross slope, giving you the ability to configure your system as the job dictates. Expand your system by adding the iCP42 and associated GNSS accessories and you have full 3D capability on your skid steer.

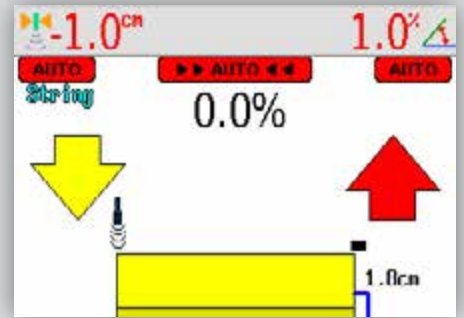

Automatic sideshift control

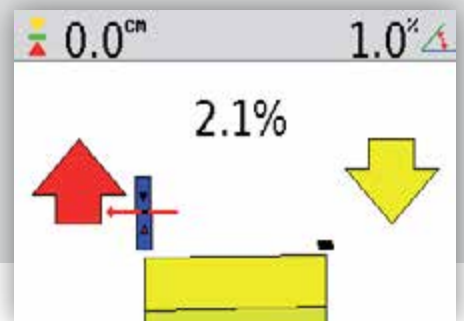

Laser and cross slope sensor

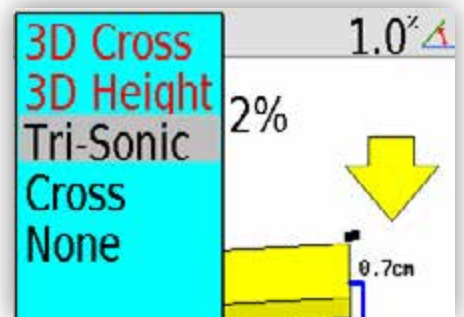

Tri-Sonic

- Maximizes machine utilization
- Remembers all your system settings
- Scalable from 2D to 3D capabilities
- Faster job cycles reduce operating costs

DRILLING SYSTEM

Maximum precision for your drilling machine.



DRILLER - 3D SYSTEM

Leica iCON iRD3

Faster and more accurate drilling jobs.

The Leica iCON iRD3 driller system puts you in full control. Guide your driller via the GNSS antennas and 3D design plans directly in the cab on the display. Automatically documenting the work as the project progresses allows you to avoid drilling in old and failed holes.

The Leica iCON iRD3 solution for drills maximizes productivity in drilling applications. Drilling rigs can be controlled easily from the cab via the control panel with 3D design plan. There is no need to stake out the positions of the holes to be drilled.

- Create drill patterns on the display
- Easily achieve directional drilling
- Log and share holes on the fly
- Log hole depth, angle, and position
- Import drill patterns from telematics

Related Products:

- Leica ConX

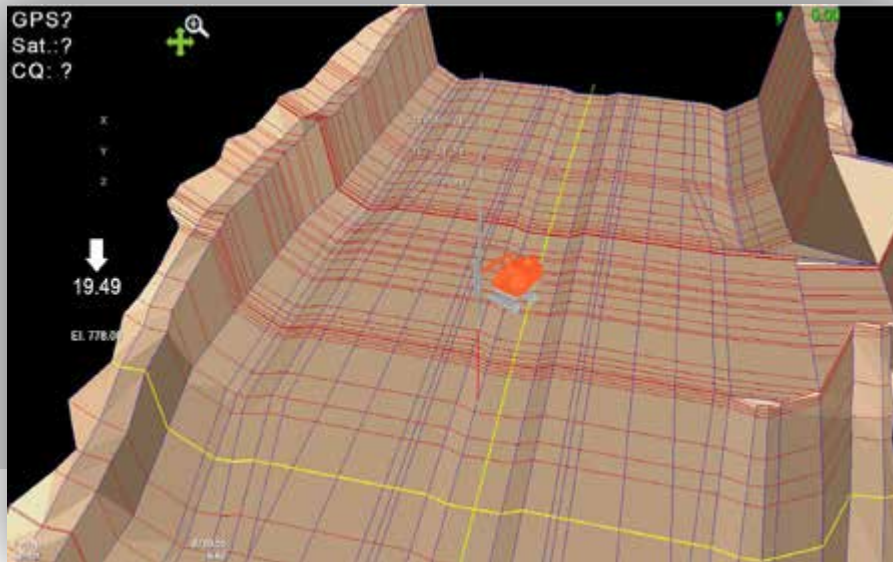

3D model, drill view

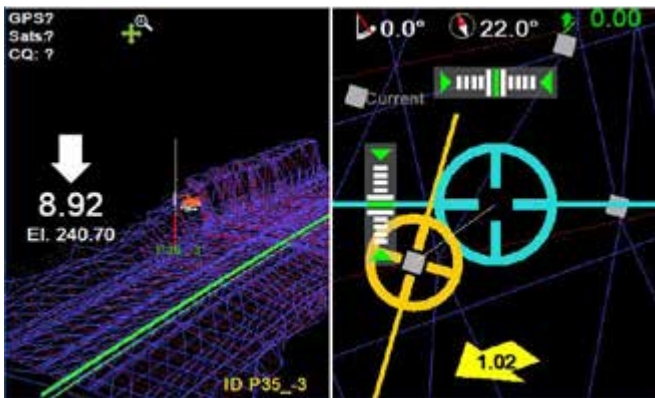

Split screen mode, 3D view with background map and navigation view



Split screen mode, 3D and navigation view

PILING SYSTEM

Ultimate control and efficiency for your pilers.

Maximize safety and cost savings with a Leica Geosystems piling system. High efficiency piling makes you more productive and enables you to use fewer people onsite, allowing you to optimize your resources. With applied documentation being automated, there is no need to survey the finished project. Save time and money with faster navigation between piles, and monitor your project progress from the comfort of your office. All in all, our piling system shortens project time and increase your efficiency.



3D System

Leica iCON iRP3

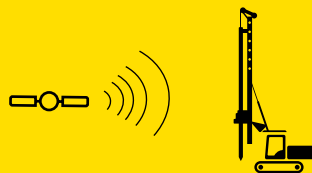

CUT DOWN ON CREWS

Huge cost savings and increased safety due to less people on the site

AUTOMATE DOCUMENTATION

As applied documentation is automated, there is no need to survey the finished project

NAVIGATE BETWEEN PILES

Save time and money with faster navigation between piles

MONITOR PROGRESS

Check on your projects progress from the comfort of your office

INCREASE EFFICIENCY

Complete large piling projects in a short time



SR-75 soilmec

СЕРВИСНО-РЕПАРАЦИОННОЕ ПРЕДПРИЯТИЕ
ПОДЪЕМНО-МОНТАЖНОЕ ОТДЕЛЕНИЕ

termarket

PILER - 3D SYSTEM

Leica iCON iRP3

Increased productivity for your piler machines.



The Leica iCON iRP3 piler system gives you maximum control. Guide your piler via the GNSS antennas and 3D design plans directly in the cab on the display. Automatically documenting the work as the project progresses means there's no need to survey the finished project.

The Leica iCON iRP3 solution for pilers maximizes productivity in piling applications. Piling rigs can be controlled easily from the cab via the control panel with 3D design plan. There is no need to stake out the positions of the sheets to be piled.

- Check project progress from the office
- Document pile positions on the fly
- Navigate faster between piles
- Reduce crew on site
- Eliminate stake-out

Related Products:

- Leica ConX



3D drill view mode

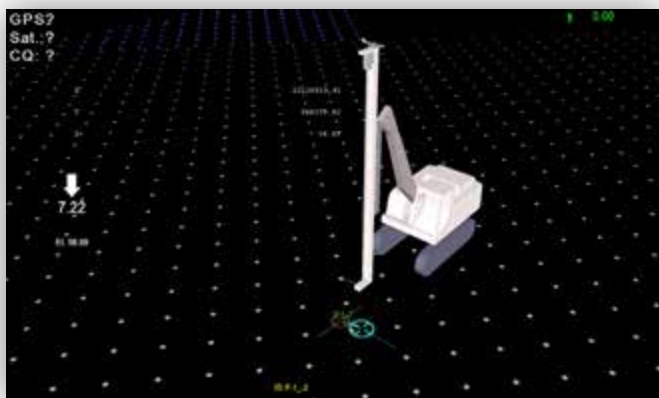

3D overview



Split screen mode, 3D model and navigation view

CONCRETE PAVING SYSTEM

The complete solution for
concrete machines.

From highways, to tunnels, to airport runways and beyond, the comprehensive Leica Geosystems solution set can be easily configured to your needs with most industry-leading paver manufacturers. Its intelligent automation, industry-leading positioning, and intuitive user interface deliver unmatched performance – giving you the edge over your competition.



3D SYSTEM

Leica iCON pave

Concrete Paving



Placer Spreader



Trimmer

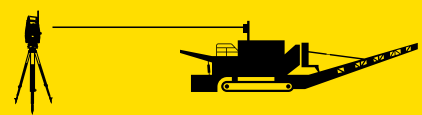



CONCRETE PAVING - 3D SYSTEM

Leica iCON pave

The ultimate in paving solutions.

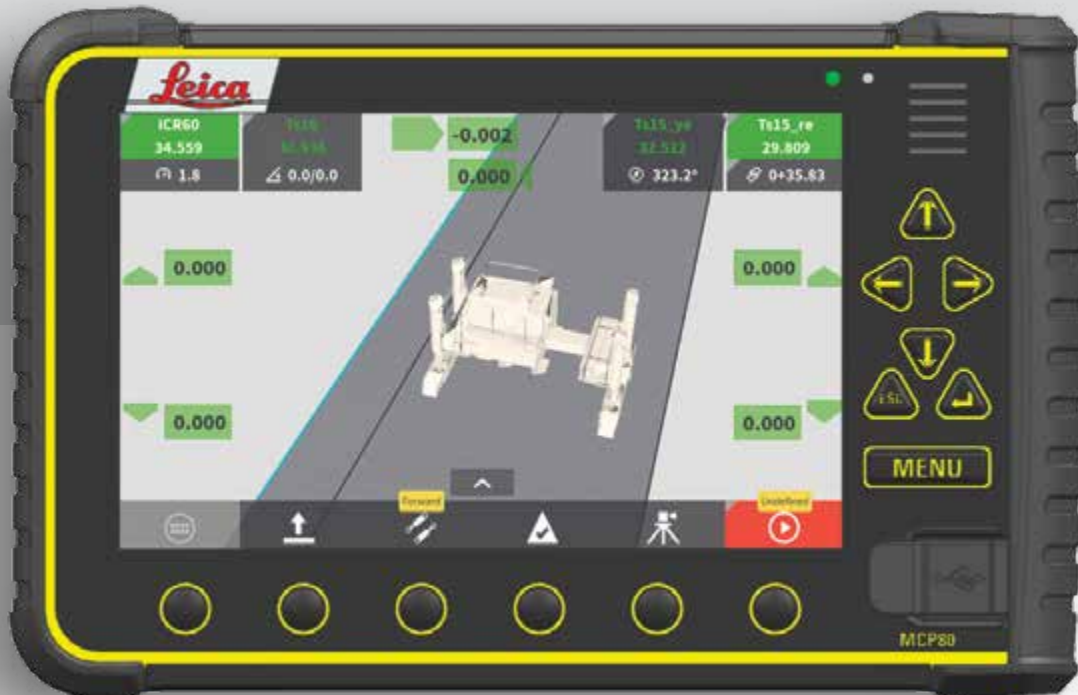

The intuitive, easy-to-use Leica iCON pave interface, combined with its powerful feature set, will put you in a whole new league. Beyond industry-leading performance and innovative prep, work process and quality control functionalities, it is one of the industry's most easy-to-learn systems.

Leica iCON pave supports your business with 3D paving solutions from airport paving to tunnel work, kerb and gutter jobs or new highway projects. Leica iCON pave for concrete paving supports all applications, such as slipform paving, kerb and gutter, trimmer, and placer spreader. Designed in cooperation with the main OEMs, Leica Geosystems ensures that the 3D paving solution meets your requirements.

- Third generation of Leica stringless paving solutions
- Consistent and highly accurate paving quality
- Easy adaption to any job site conditions with several sensor combinations
- Continuous paving operation with auto leapfrogging of total stations
- Reduced cabling and installation with the new multipoint radio
- Supported by Leica ConX for tracking, viewing and synchronization

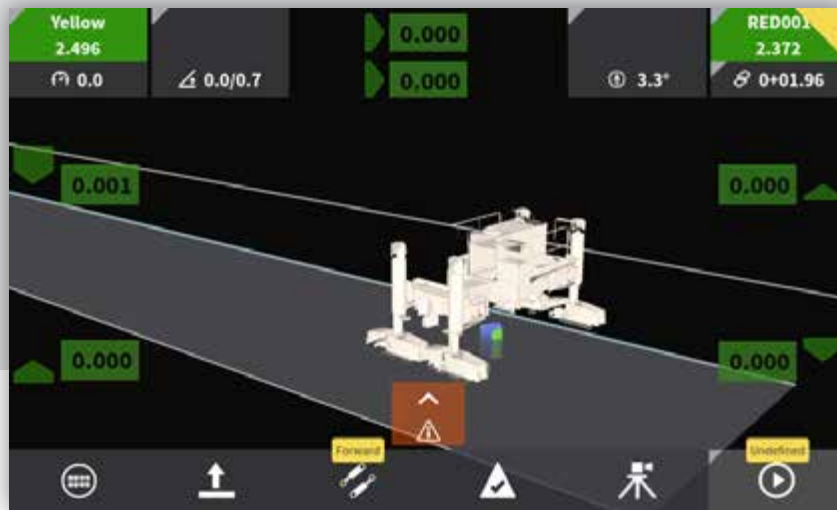

Run screen with Leica color theme



Quick access to offset run screen while in production.

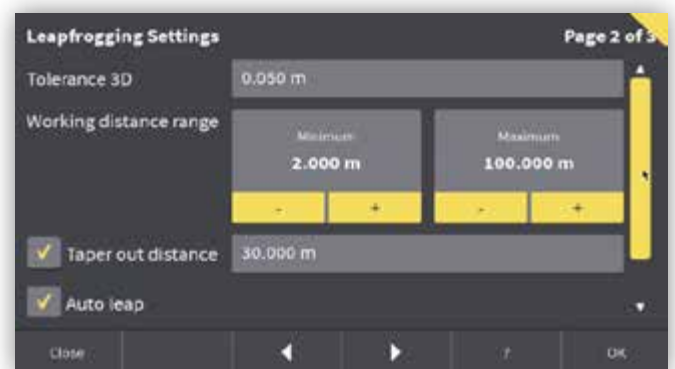

Auto leapfrogging for continuous paving process.

iCON pave supports all main Slipform paver manufacturers.
Please contact your Leica rep for details.

KERB & GUTTER SYSTEM



Take your kerb and gutter work to the next level with 3D control.

Get your kerb and gutter jobs done faster, more efficiently and right the first time with the Leica iCON machine control concrete paving solution. With decades of experience in 3D paving solutions, Leica Geosystems has proven expertise in hundreds of installed and active systems throughout the world and numerous approved interfaces with all main OEMs.

3D System

Leica iCON pave - Kerb & Gutter

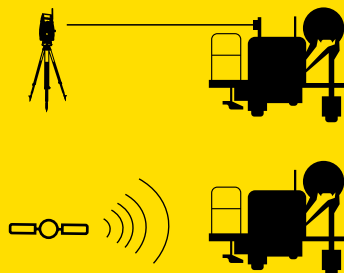



KERB & GUTTER - 3D SYSTEM

Leica iCON pave - Kerb & Gutter

The ultimate in paving solutions.

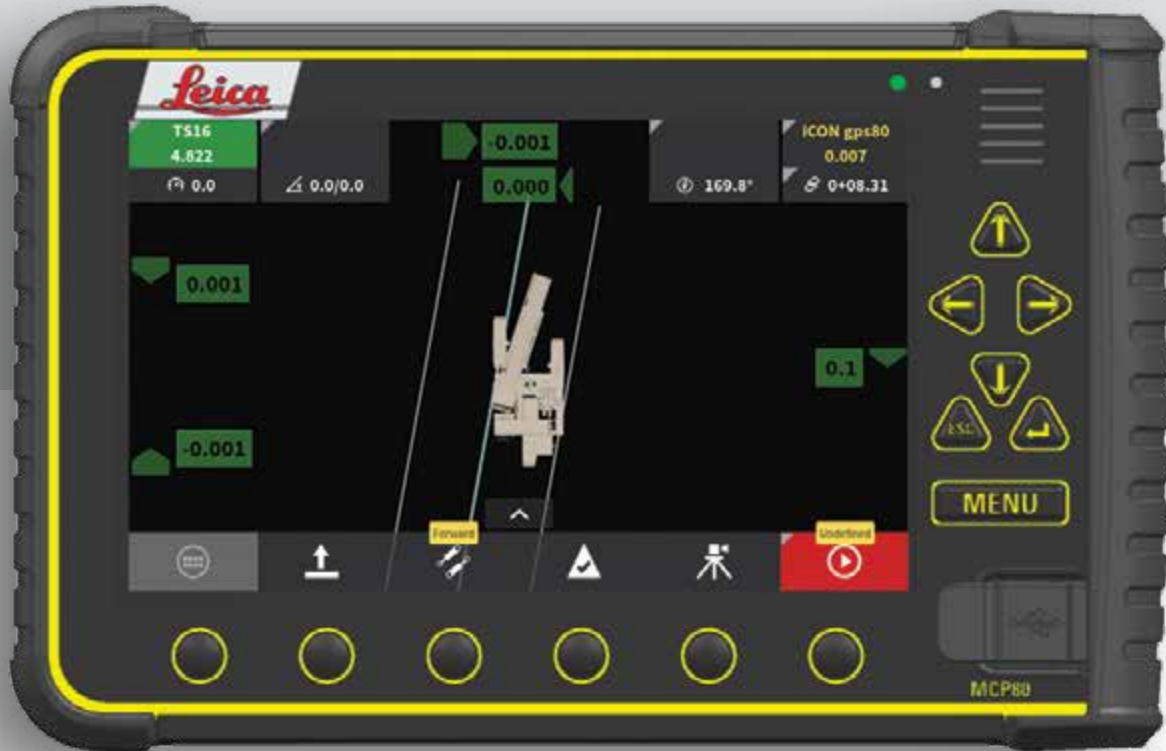

The Leica iCON pave solution simplifies your kerb and gutter application tasks. Powerful capabilities give you higher productivity, while the intuitive interface puts the user in full control of the paver. Tackle your kerb and gutter jobs with ease with the Leica iCON pave solution.

Leica Geosystems' revolutionary Kerb & Gutter solution eliminates the need to set string-lines giving you total jobsite flexibility and mobility. With its fully automated height and steer control technology you will enjoy complete freedom and unmatched accuracy. The ease-of-use and simplified setup will empower the operator and increase productivity by leaps and bounds.

- Third generation of Leica stringless paving solutions
- Consistent and highly accurate paving quality
- Easy adaption to any job site conditions with several sensor combinations
- Continuous paving operation with auto leapfrogging of total stations
- Reduced cabling and installation with the new multipoint radio
- Supported by Leica ConX for track, view and synchronization

Kerb & Gutter machine with patent filed 1Up sensor configuration. GNSS heading without the need for RTK base station or a coordinate system.



Quick access to offset run screen while in production.

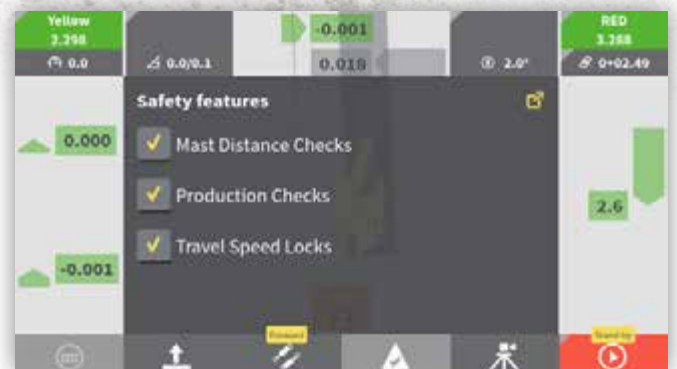

Quick access to Safety features to prevent working outside boundaries.

iCON pave supports all main Slipform paver manufacturers.
Please contact your Leica rep for details.

ASPHALT PAVING SYSTEM



The complete solution for asphalt paving machines.

Optimizing your yield has never been this easy. Take your asphalt paving to the next level with this comprehensive solution. The system can be easily operated by crews at any level of experience and configured with machines from most paving manufacturers. Combined with the system's intelligent automation, and industry-leading positioning technology, the intuitive operating experience delivers unmatched performance.

3D System

Leica PaveSmart 3D – Asphalt Paving

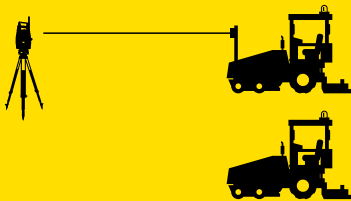



ASPHALT PAVING - 3D SYSTEM

Leica PaveSmart 3D

Get the maximum potential out of your paver.



A proven stringless system that can easily be configured to any of the major paving manufacturers available today, the Leica PaveSmart 3D system delivers millimeter accuracy in the most challenging conditions. Keep all project plans directly at your fingertips. The system can be configured with a total station or GNSS setup.

Replacing stringlines, Leica Geosystems total stations or GNSS sensors precisely track the machine's position and elevation. PaveSmart 3D calculates and compares to the design model's grade and position. Steer and elevation corrections are then sent to the machine controller, regulating the hydraulics for precise paving or milling results.

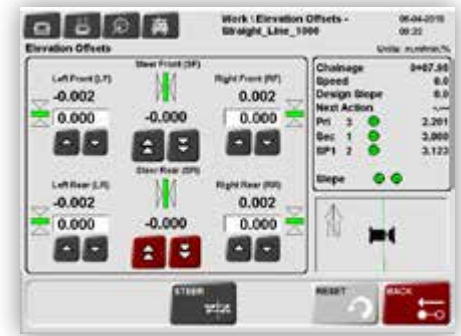

Entering offset



Select reference line



Select design reference line

Supports all MOBAmatic (PWM & CAN) and Vögele NaviTronic/ NivelTronic leveling systems and all modern asphalt paver brands.

WORKS WITH:

Vögele and all asphalt pavers with Mobamatic 1 / 2



MILLING SYSTEM



The most efficient milling system to date adds easy-to-use intelligent control and automation to your workflow.

Designed for everything from highways, to tunnels, to airport runways, and beyond, the comprehensive Leica Geosystems solution set can be easily configured to your needs with most industry-leading milling machine manufacturers. Its intelligent automation, industry-leading positioning, and intuitive user interface deliver unmatched performance – giving you the edge over your competition.

3D System

Leica PaveSmart 3D - Milling

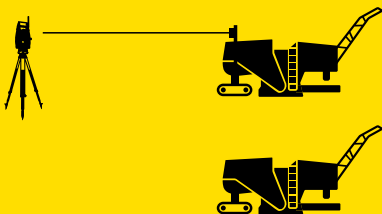



MILLING - 3D SYSTEM

Leica PaveSmart 3D - Milling

Get the maximum potential out of your paver.



Milling run screen



Select reference line



Select design reference line

Tackle your milling jobs faster and more efficiently with the Leica PaveSmart 3D system. With intelligent positioning and automated features you can take your milling jobs to the next level. The heads up display in cab puts the operator in full control.

Replacing stringlines, Leica Geosystems total stations or GNSS sensors precisely track the machine's position and elevation. PaveSmart 3D calculates and compares to the design model's grade and position. Steer and elevation corrections are then sent to the machine controller, regulating the hydraulics for precise paving or milling results.

Supports Wirtgen Level Pro (Plus) and all MOBAmatic (CAN) levelling systems and almost all modern milling machine brands.

WORKS WITH:

- Roadtec
- Wirtgen
- MOBA



Roller System

Increased efficiency for soil rollers.



Report for quality control

ROLLER - 3D SYSTEM

Leica iCON roller

Avoid over or under compaction.



Leica iCON roller solution ensures the long lasting quality of an infrastructure or building. Small quality deviations could have cost-intensive consequences if the compacted ground in each layer is not suitable for the required load. Achieve smooth compaction results every time for a long lasting foundation.

iCON roller makes the compaction work for the roller operator and the contractor easier and at lower costs, helping to achieve higher compaction quality with lower risks for any kind of deformations or cracks.

- Easily retrofittable for any roller specification
- GNSS positioning up to 2 cm accuracy in position
- Colored visualization of pass count mapping on screen
- Speed monitoring and warning for constant compaction progress
- Wireless data transfer for real-time monitoring of progress
- Job reports for quality control or payment release



HxGN SmartNet

GNSS data over the world's largest reference station network.

HxGN SmartNet is an integrated 24/7 GNSS network RTK and GNSS correction service, built on the world's largest reference network, enabling GNSS-capable devices to quickly determine precise positions.

The service is provided continuously by a highly-available infrastructure and professional support team with more than 10 years of experience reliably delivering the service. HxGN SmartNet is an open-standard correction service, able to use with any GNSS device, and is constantly monitored for integrity, availability and accuracy.

With more than 4,000 reference stations based on Leica Geosystems technology that ensure position accuracy in any application, HxGN SmartNet is easy-to-use and provides the fastest precise positions.



HxGN SmartNet was built to provide high-precision, high-availability network RTK corrections for any application, using any constellation, while at the same time being open to all. With easy access to precise correction data, Network RTK users experience the best availability, reliability and traceability using internationally recognized standards, together with flexible and affordable subscription options that meet the needs of the local market. With a robust, traceable and repeatable network RTK correction, users can expect centimeter-level accuracies. Quality of service is guaranteed through our highly sophisticated data center and monitoring systems.



Customer Care Packages

Ensure you achieve maximum value from your investment.

The relationship Leica Geosystems enjoys with its customers can be defined in one word: Partnership. That is our commitment to you.

Our job as your reliable partner is to cover all the angles; to provide quick and easy communication between site personnel and skilled experts, to keep you and your products up-to-date, and to understand the issues and anticipate your needs. Our services allow us to stay close to our customers, working together to resolve issues and plan even better product solutions for the future.

Customer Benefits

Leica Geosystems' customers benefit from a worldwide support organization that includes hotlines, web-based support, informative seminars, and customized training courses and consulting service. Benefit from direct access to our network of support professionals, obtaining the expert advice you need to work confidently and productively.

Technical Service

Leica Geosystems offers a wide range of technical services, all conducted by highly qualified technicians using professional tools. Service costs and downtime can be significantly reduced through periodic preventative maintenance, and you benefit from equipment that is always in top condition. The broad service offering includes certification services, repairs and product upgrades.

Customer Care PACKAGES >>

Leica Geosystems Customer Care Packages ensure you achieve maximum value from your investment. When you buy a CCP from Leica Geosystems, you immediately start to benefit from instant access to our network of professional support and service team while you work. With a range of three different Customer Care Packages, you will be sure to obtain the package that best suits your particular requirements and budget. From Basic to Silver, Leica Geosystems has the right Customer Care package for your business.



Leica Geosystems' information portal puts a world of information at your fingertips. myWorld provides instant access to information and knowledge that helps keep you and your Machine Control Solution up-to-date, for maximum value and efficiency. myWorld is the perfect complement to Customer Care packages.

Customer Care Packages

Available upon request.



Customer Support

Receive direct telephone and online access to our machine control professionals. They will work with you to solve any problems that may arise, whether they are operational questions, solution configuration issues or general advice.



Field Service

Annual preventative inspection of the solution carried out by experienced technicians minimizes repairs and downtime and ensures reliable machines. The annual Field Service inspection will include a visual and a system check, and a check of the calibration measurements. This gives higher up-time and more reliable machines.



Software Maintenance

Benefit from the latest software improvements and new features that keep you and your solution up-to-date to maximize productivity. Updates for your software can be retrieved from myWorld or talk to your local Leica Geosystems representative about the opportunities.



Extended Warranty

Leica Geosystems Machine Control products come standard with a one-year warranty. The coverage may be extended to a maximum of five years, covering labor and spare parts. An extended warranty provides the additional security of knowing that unplanned costs in the future can be avoided.

SHARP GRADE LEVELLER

Transform your Skid Steer / Excavator
into a Precision Laser Leveller.

SL SHARP GRADE LEVELLER

Standard Series 2.2m & 2.5m

Compact Series 1.8m & 2.0m

Junior Series 1.5m

Optional Extras

- Clip on scarifiers: Ideal for compacted surfaces, road reinstatement etc
- Clip on excavator mount: Clips to small excavators for kerb prep etc
- Adjustable centre wing: Grades narrower than standard width, offset either side
- Front angling power rake: Ideal for turf work such as golf tees etc

Curved mould board improves efficiency

Our curved mould board rolls material, greatly improving machine efficiency and fuel economy, optimizing machine size.

3D Cad Design & FEA stress analysis

Progressive Equipment utilises the latest computer technology when it comes to the design and manufacture of our equipment.

FLEXIBLE SOLUTIONS FOR YOUR BUSINESS NEEDS

We have a range of machines to suit your needs

Dual Grade:

Automatically, simultaneously adjusts the up/down and left/right plane, with manual override control. This allows complex jobs that require multiple grades or falls to be completed with ease in each pass.

Single Grade:

Designed for simplicity and ease of use, perfect for sites that require a single level.

GPS (3D):

Using 3 dimensional surfaces to automatically guide your machine to design levels, slopes & position.

TPS (3D):

The most accurate control using total stations for millimeter finishes.

Compact & Junior Series:

With a blade width of 1.8m, 1.7m or 1.5m and a retracting front wheel option, this machine is perfect for house sites, where getting into tight spots can be a real issue.

High Strength QuadRod® Linkage System

Our unique, patent-pending high strength linkage system with maintenance-free connections provides the ultimate in reliability.

- No siding plates to wear or bend
- Twin cylinders placed outboard for maximum strength and accuracy



Coverage you can count on:

Leica Geosystems is proudly distributed by C.R. Kennedy. The Largest importer and distributor of surveying equipment in Australia.

We offer a comprehensive end-to-end service from initial consultation and evaluation through to installation, training and support for the widest range of machine control and positioning applications.

Our nationwide organisation makes it possible for us to offer personal service and support wherever we are needed.

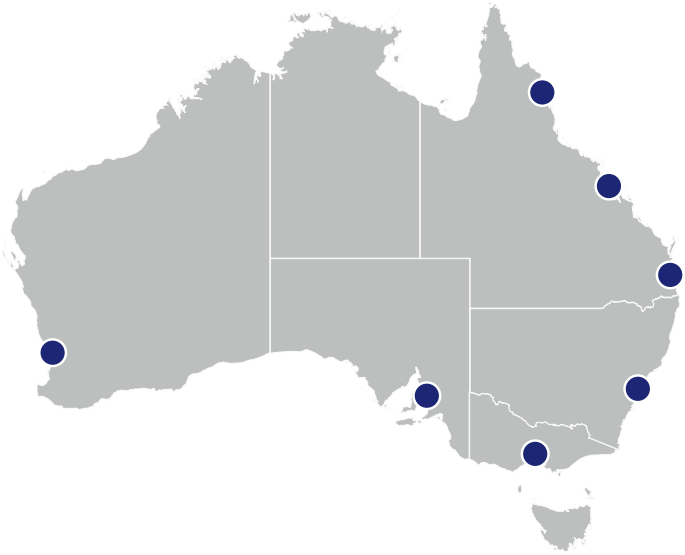

C.R. Kennedy office locations:

Victoria

300 Lorimer Street
Port Melbourne, 3207
(03) 9823 1533
vicsurvey@crkennedy.com.au

New South Wales

Level 2, 15 Bourke Road
Mascot, 2020
(02) 9552 8300
nswsurvey@crkennedy.com.au

Queensland

80 Kingsford Smith Drive
Albion, 4010
(07) 3862 6210
qldsurvey@crkennedy.com.au

Far North Queensland

Unit 1, 131 Scott Street
Cairns, 4870
(07) 4031 5399
fnqsurvey@crkennedy.com.au

Central Queensland

PO Box 4032
Mackay South, 4740
(07) 4957 6733
itrusscott@crkennedy.com.au

South Australia

77 Fullarton Road
Kent Town, 5067
(08) 8410 1366
sasurvey@crkennedy.com.au

Western Australia

Unit 1, 5 Gibberd Road
Balcatta WA 6021
(08) 9489 8500
wasurvey@crkennedy.com.au

Training

surveytraining@crkennedy.com.au

Support

surveysupport@crkennedy.com.au